

**DESCRIPTION**

Complete HEU system with concealed, Royal urinal Flushometer and vitreous china urinal.

**Flush Cycle**

Model WEUS 1015.1011-0.5 (0.5 gpf/1.9 Lpf)



Meets the American Disabilities Guidelines and ANSI A117.1 requirements when installed according to these requirements.



NOTE: Plumbing System Requirements  
√ Minimum **Flowing** Pressure: 25 PSI

**SPECIFICATIONS**

Quiet, concealed, diaphragm type, rough brass hydraulic urinal Flushometer and vitreous china urinal with the following features:

**Flushometer**

- PERMEX® Synthetic Rubber Diaphragm with Dual Filtered Fixed Bypass
- 3/4" I.P.S. Wheel Handle Bak-Chek® Angle Stop
- High Back Pressure Vacuum Breaker
- Spud Coupling for 3/4" Concealed Back Spud Urinal
- Elbow Flush Connection
- Exposed Parts Chrome Plated
- High copper, low zinc brass castings for dezincification resistance
- Flush accuracy controlled by CID® technology
- Diaphragm, Stop Seat and Vacuum Breaker to be molded from PERMEX® rubber compound for chloramine resistance
- Valve Body, Tailpiece and Control Stop shall be in conformance with ASTM Alloy Classification for Semi-Red Brass. Valve shall be in compliance with the applicable sections of ASSE 1037, ANSI/ASME A112.19.2.

**Urinal**

- Wall mounted Vitreous china
- Washdown flushing action and Integral flushing rim
- 3/4" rear spud inlet
- 100% factory flush tested
- All mounting hardware included
- Carrier not included
- Compatible with Jay R. Smith Carrier: 0636 & 0637

These products when installed as a combination as shown, meet the "Buy American Act" requirements

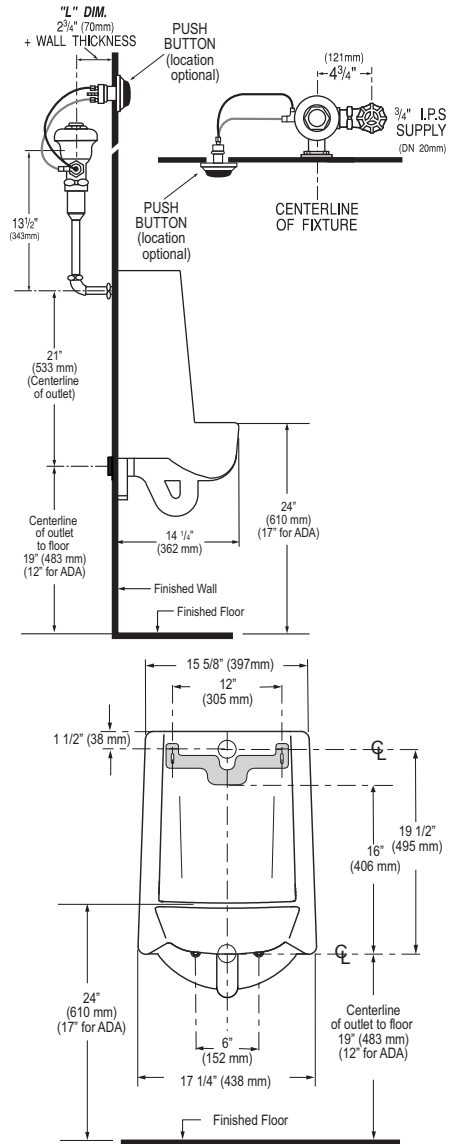

This space for Architect/Engineer approval	
Job Name	Date
Model Specified	Quantity
Variations Specified	
Customer/Wholesaler	
Contractor	
Architect	

The information contained in this document is subject to change without notice.

Made In The  
**USA**



Sloan Valve Company is buying renewable energy certificates to meet 100% of the company's purchased electricity use at its Franklin Park, Illinois facility.

**SLOAN**

Sloan Valve Company  
10500 Seymour Avenue  
Franklin Park, IL 60131  
Phone: 1-800-9-VALVE-9 (982-5839)  
or 1-847-671-4300  
Fax: 1-800-447-8329 or 1-847-671-4380  
www.sloanvalve.com

Copyright © 2009 Sloan Valve Company  
Printed in the U.S.A. Rev. 0a (08/09)