

DESCRIPTION

Complete system with Battery Powered, Sensor Operated G2® OPTIMA Plus® urinal Flushometer and vitreous china urinal.

Flush Cycle

Model WEUS 1006.1401-1.0 G2® (1.0 gpf/3.8 Lpf)



Meets the American Disabilities Guidelines and ANSI A117.1 requirements when installed according to these requirements.



NOTE: Plumbing System Requirements
√ Minimum **Flowing** Pressure: 25 PSI

SPECIFICATIONS

Quiet, exposed, diaphragm type, chrome plated urinal Flushometer for either left or right hand supply with the following features:

Flushometer

- PERMEX® Synthetic Rubber Diaphragm with Dual Filtered Fixed Bypass
- Flex Tube Diaphragm designed for improved life and reduced maintenance
- ADA Compliant OPTIMA Plus® Battery Powered Infrared Sensor for automatic "No Hands" operation
- Infrared Sensor with Multiple-focused, Lobular Sensing Fields for high and low target detection
- Latching Solenoid Operator
- Engineered Metal Cover with replaceable Lens Window
- Courtesy Flush™ Override Button
- Four (4) Size AA Batteries factory installed
- "Low Battery" Flashing LED
- Infrared Sensor Range Adjustment Screw
- Initial Set-up Range Indicator Light (first 10 minutes)
- Chrome Plated Metal Handle Cap
- 3/4" I.P.S. Screwdriver Bak-Chek® Angle Stop
- High Back Pressure Vacuum Breaker Flush Connection with One-piece Bottom Hex Coupling Nut
- Spud Coupling and Flange for 3/4" Top Spud
- Sweat Solder Adapter w/Cover Tube and Cast Wall Flange w/Set Screw
- High copper, low zinc brass castings for dezincification resistance
- Fixed Metering Bypass and no external volume adjustment to ensure water conservation
- Flush Accuracy Controlled by CID® Technology
- Diaphragm, Stop Seat and Vacuum Breaker to be molded from PERMEX® rubber compound for chloramine resistance
- Valve Body, Tailpiece and Control Stop shall be in conformance with ASTM Alloy Classification for Semi-Red Brass. Valve shall be in compliance with the applicable sections of ASSE 1037, ANSI/ ASME A112.19.2. Installation conforms to ADA requirements.

Urinal

- Wall hung vitreous china
- Washdown flushing action
- 3/4" I.P.S. top spud inlet
- 2" NPT outlet flange
- All mounting hardware included
- Integral flushing rim
- 100 % factory flush tested
- Compatible with Jay R. Smith Carrier 0636 or 0637



These products when installed as a combination as shown, meet the "Buy American Act" requirements

FEATURES

ADA Compliant

Automatic

Sloan G2 OPTIMA Plus® Flushometers activate via multi-lobular sensor detection to provide the ultimate in sanitary protection and automatic operation. A battery powered infrared sensor sets the flushing mechanism after the user is detected and completes the flush when the user steps away.

Functional & Hygienic

Touchless, sensor operation eliminates the need for user contact to help control the spread of infectious diseases. The G2 OPTIMA Plus® Flushometer is provided with an Override Button to allow a "courtesy flush" for individual user comfort.

Economical

Sloan installed batteries speed installation and provide years of metered flushing to control the use of water and energy. Batteries can be changed without turning off the water.

Warranty

3 year (limited)

Made In The
USA



Sloan Valve Company is buying renewable energy certificates to meet 100% of the company's purchased electricity use at its Franklin Park, Illinois facility.

SLOAN.

Sloan Valve Company
10500 Seymour Avenue
Franklin Park, IL 60131
Phone: 1-800-9-VALVE-9 (982-5839)
or 1-847-671-4300
Fax: 1-800-447-8329 or 1-847-671-4380
www.sloanvalve.com

Copyright © 2009 Sloan Valve Company
Printed in the U.S.A. Rev. 0a (08/09)

This space for Architect/Engineer approval	
Job Name	Date
Model Specified	Quantity
Variations Specified	
Customer/Wholesaler	
Contractor	
Architect	

DESCRIPTION

Complete system with Battery Powered, Sensor Operated G2® OPTIMA Plus® urinal Flushometer and vitreous china urinal.

Flush Cycle

Model WEUS 1006.1401-1.0 G2® (1.0 gpf/3.8 Lpf)

ELECTRICAL SPECIFICATIONS

- **Control Circuit**
Solid state
6 VDC input
8 second arming delay
24 hour Sentinel Flush
- **OPTIMA Sensor Type**
Active infrared
- **OPTIMA® Sensor Range**
Nominal 15" – 30" (381 mm – 762 mm),
Adjustable ± 8" (203 mm)
- **Battery Type**
(4) AA Alkaline
- **Battery Life**
3 Years @ 4,000 flushes/month
- **Indicator Lights**
Range adjustment/low battery
- **Operating Pressure**
15 – 100 psi (104 – 689 kPa)
- **Sentinel Flush**
Once every 24 hours after the last flush

OPERATION

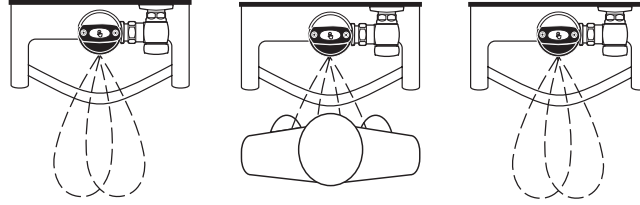

1. A continuous, invisible light beam is emitted from the OPTIMA Plus® Sensor.
2. As the user enters the beam's effective range (15" to 30") the beam is reflected into the OPTIMA Plus Scanner Window and transformed into a low voltage electrical circuit. Once activated, the Output Circuit continues in a "hold" mode for as long as the user remains within the effective range of the Sensor.
3. When the user steps away from the OPTIMA Plus® Sensor, the Sensor initiates an electrical signal that operates the Solenoid. This initiates the flushing cycle to flush the fixture. The Circuit then automatically resets and is ready for the next user.

DIMENSIONS/ROUGH-IN

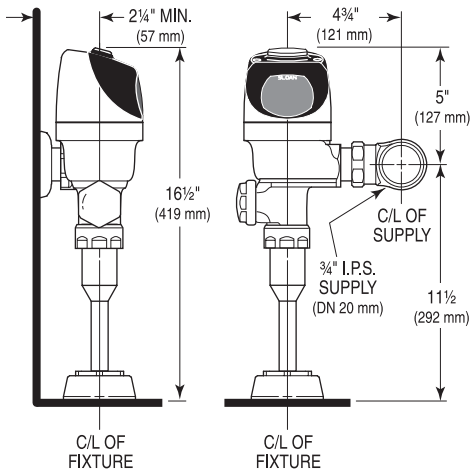

Note: Lens Deflector no longer needed for targeting children or wheelchair users.

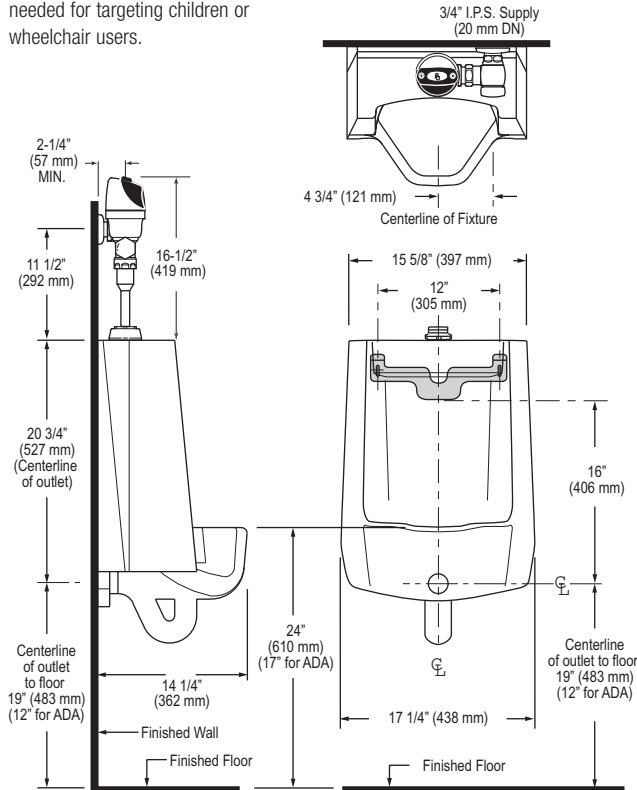

SLOAN®

Sloan Valve Company
10500 Seymour Avenue
Franklin Park, IL 60131
Phone: 1-800-9-VALVE-9 (982-5839)
or 1-847-671-4300
Fax: 1-800-447-8329 or 1-847-671-4380
www.sloanvalve.com