



Efficiency Series

Model

# WETS 2060.1311-1.28 ES-S

OPTIMA® Systems Concealed Sensor Operated HET Flushometer and Wall Hung Water Closet

## DESCRIPTION

Complete HET system with concealed, sensor activated, Royal® OPTIMA® closet Flushometer and vitreous china wall hung rear spud water closet.

### Flush Cycle

Model WETS 2060.1311-1.28-ES-S (1.28 gpf/4.8 Lpf)



Meets the American Disabilities Guidelines and ANSI A117.1 requirements when installed according to these requirements.



### NOTE:

Plumbing System Requirements

- Minimum **Flowing** Pressure: 25 PSI
- Minimum Flow Rate: 18 GPM

## SPECIFICATIONS

Quiet, concealed, sensor operated diaphragm type, rough brass closet Flushometer for either left or right hand supply and vitreous china wall hung water closet with the following features:

### Flushometer and OPTIMA® ES-S Unit

- PERMEX™ Synthetic Rubber Diaphragm with Dual Filtered Fixed Bypass
- OPTIMA® EL-1500-L Self-Adaptive Infrared Sensor with Indicator Light
- User friendly three (3) second Flush Delay
- Courtesy Flush™ Override Button
- Non-Hold-Open Integral Solenoid Operator
- Die cast sensor plate with no visible fasteners (for 2-gang electrical box)
- High Back Pressure Vacuum Breaker Flush Connection and Spud Coupling for 1-1/2" concealed back Spud
- Sweat Solder Adapter
- High Copper, Low Zinc Brass Castings for Dezincification Resistance
- Non-Hold-Open Integral Solenoid Operator, Fixed Metering Bypass and No External Volume Adjustment to Ensure Water Conservation
- Flush Accuracy Controlled by CID™ Technology
- Diaphragm, Stop Seat and Vacuum Breaker to be molded from PERMEX™ Rubber Compound for Chloramine Resistance
- Valve Body, Cover, Tailpiece and Control Stop shall be in conformance with ASTM Alloy Classification for Semi-Red Brass. Valve shall be in compliance with the applicable sections of ASSE 1037, ANSI/ASME A112.19.2. Installation conforms to ADA requirements.

### Water Closet

- Wall hung vitreous china elongated bowl
- Siphon jet flushing action
- 1-1/2" rear spud inlet
- 2" fully glazed trapway diameter
- Integral flushing rim
- Water spot area 9 1/2" x 8 1/4"
- Mounting hardware, carrier and toilet seat not included
- Compatible with toilet seat models: Olsonite 10CT, Bemis 1955CT & Church Commercial 295CT
- Water closet shall be in compliance to the applicable sections of ASME A112.19.2/CSA B45.1



These products when installed as a combination as shown, meet the "Buy American Act" requirements

## FEATURES

### Automatic

Sloan OPTIMA® equipped Flushometers provide the ultimate in sanitary protection and automatic operation. There are no handles to trip or buttons to push. The Flushometer operates by means of an infrared sensor that adapts to its surroundings. Once the user enters the sensor's effective range and then steps away, the Flushometer Solenoid initiates the flushing cycle to flush the fixture.

### Hygienic

User makes no physical contact with the Flushometer surface. Helps control the spread of infectious diseases. 24-hour Sentinel Flush keeps fixture fresh during periods of nonuse.

### Economical

Automatic operation provides water usage savings over other flushing devices. Reduces maintenance and operation costs.

### Practical

Solid state electronic circuitry assures years of dependable, trouble-free operation. The operational components of the Flushometer are identical to a handle operated Royal® Flushometer, proven by more than 100 years of experience.

### Warranty

3 year (limited)

Made In The  
**USA**



Sloan Valve Company is buying renewable energy certificates to meet 100% of the company's purchased electricity use at its Franklin Park, Illinois facility.



Sloan Valve Company  
10500 Seymour Avenue  
Franklin Park, IL 60131  
Phone: 1-800-9-VALVE-9 (982-5839)  
or 1-847-671-4300  
Fax: 1-800-447-8329 or 1-847-671-4380  
www.sloanvalve.com

Copyright © 2009 Sloan Valve Company  
Printed in the U.S.A. Rev. 0a (09/09)

This space for Architect/Engineer approval	
Job Name _____	Date _____
Model Specified _____	Quantity _____
Variations Specified _____	
Customer/Wholesaler _____	
Contractor _____	
Architect _____	

The information contained in this document is subject to change without notice.

### DESCRIPTION

Complete HET system with concealed, sensor activated, Royal® OPTIMA® closet Flushometer and vitreous china wall hung water closet.

#### Flush Cycle

Model WETS 2060.1311-1.28-ES-S  
(1.28 gpf/4.8 Lpf)

### ELECTRICAL SPECIFICATIONS

- **Control Circuit**  
Solid State  
24 VAC Input  
24 VAC Output  
8 Second Arming Delay  
24 Hour Sentinel Flush
- **OPTIMA® Sensor Range**  
Nominal 22" – 42" (559 mm – 1067 mm)  
Self-adaptive Window ± 10" (254 mm)
- **Solenoid Operator**  
24 VAC, 50/60 Hz
- **Transformer Accessories**  
EL-154 Transformer (120 VAC/24 VAC 50 VA)  
EL-342 Transformer (240 VAC/24 VAC 50 VA)

### DIMENSIONS/ROUGH-IN

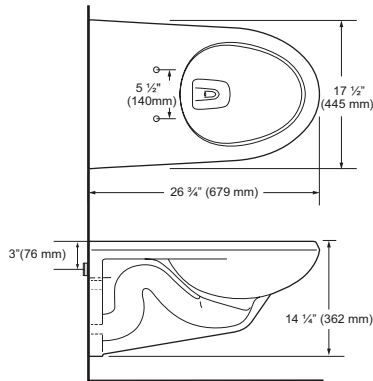

### OPERATION

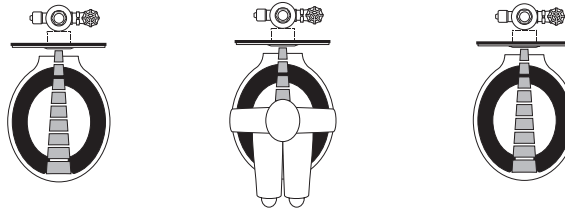

1. A continuous, invisible light beam is emitted from the OPTIMA® Sensor.
2. As the user enters the beam's effective range (22" to 42") the beam is reflected into the OPTIMA® Scanner Window and transformed into a low voltage electrical circuit. Once activated, the Output Circuit continues in a "hold" mode for as long as the user remains within the effective range of the sensor.
3. When the user steps away from the OPTIMA® Sensor, the circuit immediately initiates an electrical "one-time" signal that operates the Solenoid. This initiates the flushing cycle to flush the fixture. The Circuit then automatically resets and is ready for the next user.

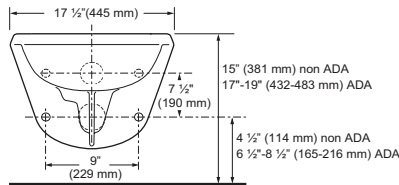
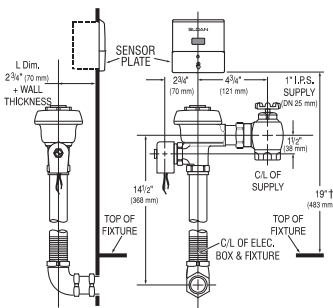

### WIRING DIAGRAM

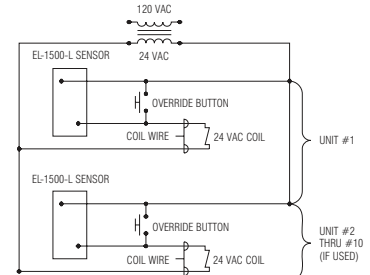

One Transformer serves up to ten (10) OPTIMA Closet/Urinal Flushometers. Specify number of transformers required accordingly.

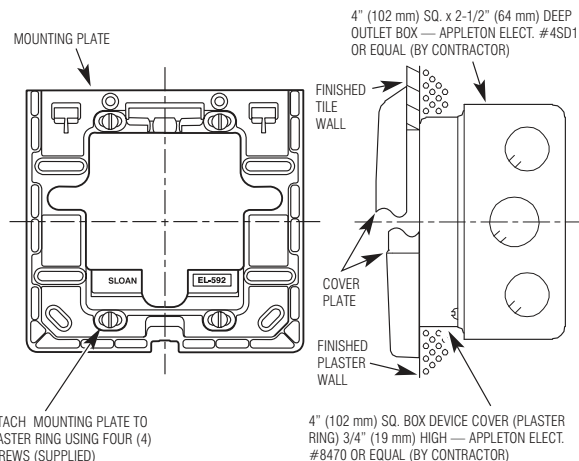

ATTACH MOUNTING PLATE TO PLASTER RING USING FOUR (4) SCREWS (SUPPLIED)

4" (102 mm) SQ. BOX DEVICE COVER (PLASTER RING) 3/4" (19 mm) HIGH — APPLETON ELECT. #8470 OR EQUAL (BY CONTRACTOR)

To ensure a perfect rough-in, Sloan recommends the use of the EL-485-A Flushometer electrical box positioning and support kit. Specify and order the EL-485-A kit separately. Consult factory for installation details.