

Model
WETS 2053.1401-1.6 G2®
OPTIMA Plus® Systems Sensor Activated Flushometer and Wall Hung Water Closet

DESCRIPTION

Complete system with Battery Powered, Sensor Activated G2® OPTIMA Plus® closet Flushometer and vitreous china wall hung fixture.

Flush Cycle

Model WETS 2053.1401-1.6 G2® (1.6 gpf/6.0 Lpf)



Meets the American Disabilities Guidelines and ANSI A117.1 requirements when installed according to these requirements.



NOTE:

Plumbing System Requirements

- Minimum **Flowing** Pressure: 25 PSI
- Minimum Flow Rate: 18 GPM

SPECIFICATIONS

Quiet, exposed, sensor activated diaphragm type, chrome plated closet Flushometer for either left or right hand supply and vitreous china wall hung water closet with the following features:

Flushometer

- PERMEX® Synthetic Rubber Diaphragm with Dual Filtered Fixed Bypass
- Flex Tube Diaphragm designed for improved life and reduced maintenance
- ADA Compliant OPTIMA Plus® Battery Powered Infrared Sensor for automatic "No Hands" operation
- Infrared Sensor with Multiple-focused, Lobular Sensing Fields for high and low target detection
- Latching Solenoid Operator
- Engineered Metal Cover with replaceable Lens Window
- Courtesy Flush™ Override Button
- Four (4) Size AA Batteries factory installed
- "Low Battery" Flashing LED
- Infrared Sensor Range Adjustment Screw
- Initial Set-up Range Indicator Light (first 10 minutes)
- Chrome Plated Metal Handle Cap
- 1" I.P.S. Screwdriver Bak-Chek® Angle Stop
- High Back Pressure Vacuum Breaker Flush Connection with One-piece Bottom Hex Coupling Nut
- Spud Coupling and Flange for 1-1/2" Top Spud
- Sweat Solder Adapter w/Cover Tube and Cast Wall Flange w/Set Screw
- High copper, low zinc brass castings for dezincification resistance
- Fixed Metering Bypass and no external volume adjustment to ensure water conservation
- Flush Accuracy Controlled by CID® Technology
- Diaphragm, Stop Seat and Vacuum Breaker to be molded from PERMEX® rubber compound for chloramine resistance
- Valve Body, Tailpiece and Control Stop shall be in conformance with ASTM Alloy Classification for Semi-Red Brass. Valve shall be in compliance with the applicable sections of ASSE 1037.

SPECIFICATIONS (CONTINUED)

Fixture

- Wall hung vitreous china elongated bowl
- Siphon jet flushing action
- 1-1/2" I.P.S. top spud inlet
- 2 1/8" fully glazed trapway diameter
- Integral flushing rim
- Water spot area 9 1/2" x 8 1/4"
- Mounting hardware, carrier and toilet seat not included
- Compatible with toilet seat models: Olsonite 10CT, Bemis 1955CT & Church Commercial 295CT
- Compatible with carrier model: Jay R. Smith 0210Y-M54
- Water closet shall be in compliance to the applicable sections of ASME A112.19.2/CSA B45.1
- Compliant with the Buy American Act when purchased as a combination

FEATURES

Automatic

Sloan OPTIMA Plus® equipped Flushometers provide the ultimate in sanitary protection and automatic operation. There are no handles to trip or buttons to push. The Flushometer operates by means of an infrared sensor that adapts to its surroundings. Once the user enters the sensor's effective range and then steps away, the Flushometer Solenoid initiates the flushing cycle to flush the fixture.

Hygienic

User makes no physical contact with the Flushometer surface. Helps control the spread of infectious diseases. 24-hour Sentinel Flush keeps fixture fresh during periods of nonuse.

Economical

Automatic operation provides water usage savings over other flushing devices.

Practical

Solid state electronic circuitry assures years of dependable, trouble-free operation. Proven by more than 100 years of experience.

Warranty

3 year (limited)

G2® Flushometer U.S. Patent No. D598, 974



Sloan Valve Company is buying renewable energy certificates to meet 100% of the company's purchased electricity use at its Franklin Park, Illinois facility.

SLOAN®

Sloan Valve Company
10500 Seymour Avenue
Franklin Park, IL 60131
Phone: 1-800-9-VALVE-9 (982-5839)
or 1-847-671-4300
Fax: 1-800-447-8329 or 1-847-671-4380
www.sloanvalve.com

Copyright © 2010 Sloan Valve Company
Rev. 0b (06/10)

This space for Architect/Engineer approval	
Job Name	Date
Model Specified	Quantity
Variations Specified	
Customer/Wholesaler	
Contractor	
Architect	

DESCRIPTION

Complete system with Battery Powered, Sensor Activated G2® OPTIMA Plus® closet Flushometer and vitreous china wall hung fixture.

Flush Cycle

Model WETS 2053.1401-1.6 G2® (1.6 gpf/6.0 Lpf)

ELECTRICAL SPECIFICATIONS

- **Control Circuit**
Solid state
6 VDC input
8 second arming delay
24 hour Sentinel Flush
- **OPTIMA Sensor Type**
Active infrared
- **OPTIMA® Sensor Range**
Nominal 22" – 42" (559 mm – 1067 mm),
Adjustable ± 8" (203 mm)
- **Battery Type**
(4) AA Alkaline
- **Battery Life**
3 Years @ 4,000 flushes/month
- **Indicator Lights**
Range adjustment/low battery
- **Operating Pressure**
15 – 100 psi (104 – 689 kPa)
- **Sentinel Flush**
Once every 24 hours after the last flush

OPERATION

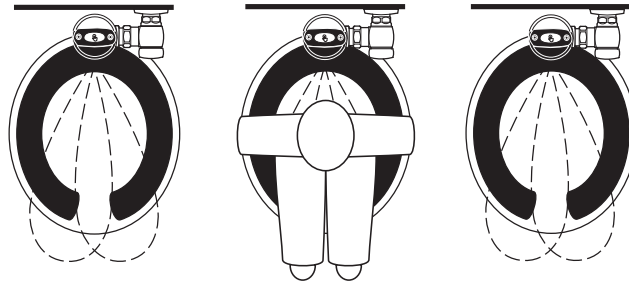

1. A continuous, invisible light beam is emitted from the OPTIMA Plus® Sensor.
2. As the user enters the beam's effective range (22" to 42") the beam is reflected into the OPTIMA Plus® Scanner Window and transformed into a low voltage electrical circuit. Once activated, the Output Circuit continues in a "hold" mode for as long as the user remains within the effective range of the Sensor.
3. When the user steps away from the OPTIMA Plus® Sensor, the circuit waits 3 seconds (to prevent false flushing) then initiates an electrical signal that operates the Solenoid. This initiates the flushing cycle to flush the fixture. The Circuit then automatically resets and is ready for the next user.

DIMENSIONS/ROUGH-IN

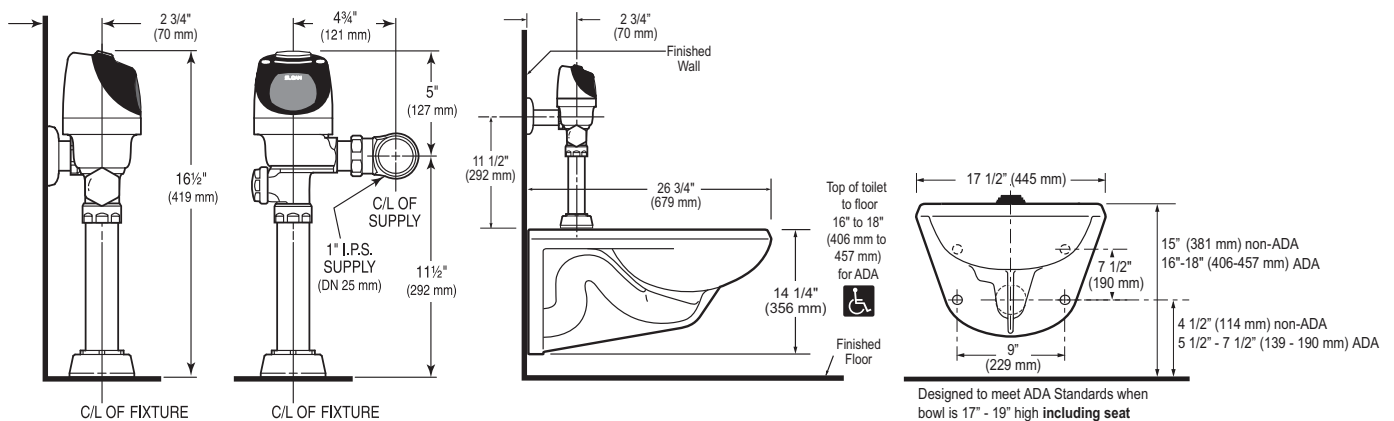

SLOAN VALVE COMPANY • 10500 SEYMOUR AVENUE • FRANKLIN PARK, IL 60131

Phone: 1-800-9-VALVE-9 or 1-847-671-4300 • Fax: 1-800-447-8329 or 1-847-671-4380 • www.sloanvalve.com