

► **Description**

Exposed, Solar Powered, Sensor Activated Sloan SOLIS® Dual Flush Model Water Closet Flushometer for back inlet squat toilets.

► **Flush Cycle**

- Full Flush (Large Button) / 1.6 gpf/6.0 Lpf
- Reduced Flush (Small Button) / 1.1 gpf/4.2 Lpf

► **Specifications**

- Quiet, Exposed, Diaphragm Type, Chrome Plated Closet Flushometer for either left or right hand supply with the following features:
- Solar Powered. The sensor assembly is powered by a solar cell that will harvest power from artificial indoor light, either incandescent or fluorescent light, and use it as the energy source. The solar cell can provide approximately 100% power with 650 Illuminance (lux).
 - Four (4) Size AA Battery Back-up Power Source
 - "Low Battery" Flashing LED
 - If the user is present for less than one minute and leaves the sensing zone or chooses the small override button, a reduced flush initiates (1.1 gpf/4.2 Lpf) eliminating liquid and paper waste, saving 1/2 gallon of water
 - If the user is present for greater than one minute and leaves the zone or chooses the large override button, the full flush initiates (1.6 gpf/ 6.0 Lpf) eliminating solid waste and paper
 - Reduces water volume by up to 30% when a reduced flush occurs
 - PERMEX™ Synthetic Rubber Diaphragm with twin linear filtered bypass and vortex cleansing action
 - Flex Tube Diaphragm designed for improved life and reduced maintenance
 - ADA Compliant Sloan Solis® Electronic Dual Flush Solar Powered Infrared Sensor for automatic "No Hands" operation
 - Infrared Sensor with Multiple-focused, Lobular Sensing Fields for high and low target detection
 - Latching Solenoid Operator
 - Engineered Metal Cover with replaceable Lens Window
 - User friendly three (3) second Flush Delay
 - Courtesy Flush™ Override Buttons
 - Infrared Sensor Range Adjustment Screw
 - Initial Set-up Range Indicator Light (first 10 minutes)
 - 1" I.P.S. Screwdriver Bak-Chek® Angle Stop
 - Free Spinning, Vandal Resistant Stop Cap
 - Adjustable Tailpiece
 - High Back Pressure Vacuum Breaker Flush Connection with One-piece Bottom Hex Coupling Nut
 - Sweat Solder Adapter w/Cover Tube and Cast Wall Flange w/Set Screw
 - High Copper, Low Zinc Brass Castings for Dezincification Resistance
 - Fixed Metering Bypass and No External Volume Adjustment to Ensure Water Conservation
 - Flush Accuracy Controlled by CID™ Technology
 - Diaphragm, Stop Seat and Vacuum Breaker molded from PERMEX™ Rubber Compound for Chloramine resistance
 - 100% of the energy used in manufacturing is offset with Renewable Energy Sources – Wind Energy

Valve Body, Tailpiece and Control Stop shall be in conformance with ASTM Alloy Classification for Semi-Red Brass. Valve shall be in compliance with the applicable sections of ASSE 1037, ANSI/ASME A112.19.2 and Military Specification V-29193. Installation conforms to ADA requirements.

► **Special Finishes**

- PB** Polished Brass (PVD Finish)
- GP** Gold Plate (PVD Finish)
- BN** Brushed Nickel (PVD Finish)
- SF** Satin Chrome

See Accessories Section and Sloan SOLIS® Dual Flush Accessories Section of the Sloan catalog for details on these and other Sloan Solis® Dual Flush Flushometer variations.



► **ADA Compliant**

► **Automatic Operation**

Sloan SOLIS® Solar powered, Dual Flush Flushometers can also be activated via multi-lobular infrared sensor. By detecting user presence and duration, the Sloan Solis® Smart Sense Technology™ will determine the proper flush volume for unequalled water efficiency.

► **Manual Operation**

Sloan SOLIS® Solar powered, Dual Flush Flushometers incorporate intuitive Split-button design for easy manual activation. The small button controls the reduced flush cycle (1.1 gpf/4.2 Lpf), the large button controls the full flush cycle (1.6 gpf/ 6.0 Lpf). Straightforward graphics alert user to proper activation. Reduced flush for liquid waste, full flush for solid waste. To further educate the user, two (2) instructional wall plates are included with each Sloan Solis® Flushometer.

► **Functional & Hygienic**

Touchless, sensor operation eliminates the need for user contact to help control the spread of infectious diseases. The Sloan SOLIS® Solar powered, Dual Flush Flushometers are provided with *Reduced* or *Full* Flush Override Buttons to allow a "courtesy flush" for individual user comfort.

► **Warranty**

3 year (limited)



This space for Architect/Engineer approval

Job Name _____ Date _____

Model Specified _____ Quantity _____

Variations Specified _____

Customer/Wholesaler _____

Contractor _____

Architect _____



Sloan Valve Company is buying renewable energy certificates to meet 100% of the company's purchased electricity use at its Franklin Park, IL, facility.

- ▶ **Description**
Exposed, Solar Powered, Sensor Activated Sloan SOLIS® Dual Flush Model Water Closet Flushometer for back inlet squat toilets.
- ▶ **Flush Cycle**
 - Full Flush (Large Button) / 1.6 gpf/6.0 Lpf
 - Reduced Flush (Small Button) / 1.1 gpf/4.2 Lpf

ELECTRICAL SPECIFICATIONS

- ▶ **Control Circuit**
Solid State
6 VDC Input
8 Second Arming Delay
3 Second Flush Delay
- ▶ **Sloan Solis® Dual Flush Sensor Type**
Active Infrared
- ▶ **Sloan Solis® Dual Flush Sensor Range**
Nominal 22" - 42" (559 mm -1067 mm), Adjustable ± 8" (203 mm)
- ▶ **Battery Back Up Type**
(4) AA Alkaline
- ▶ **Battery Life**
6 Years @ 4,000 Flushes/Month
- ▶ **Indicator Lights**
Range Adjustment/Low Battery
- ▶ **Operating Pressure**
15 - 100 psi (104 - 689 kPa)
- ▶ **Sentinel Flush**
Once Every 72 Hours After the Last Flush

OPERATION

1. A continuous, invisible light beam is emitted from the Sloan Solis® Dual Flush Sensor.

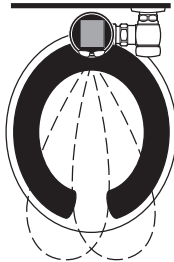

2. As the user enters the beam's effective range, 22 to 42 inches (559 mm to 1067 mm), the beam is reflected into the Scanner Window to activate the Output Circuit. Once activated, the Output Circuit continues in a "hold" mode for as long as the user remains within the effective range of the sensor. If the user stays longer than 65 seconds, a full flush will automatically initiate when the user leaves.

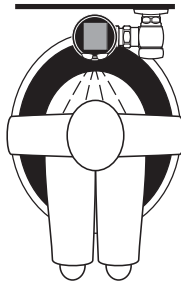

3. Once a user is detected, if the user leaves in 65 seconds or less, a reduced flush will automatically initiate. The circuit automatically resets and is ready for the next user.

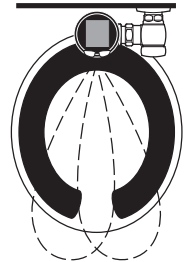

VALVE ROUGH-IN

Model 8137

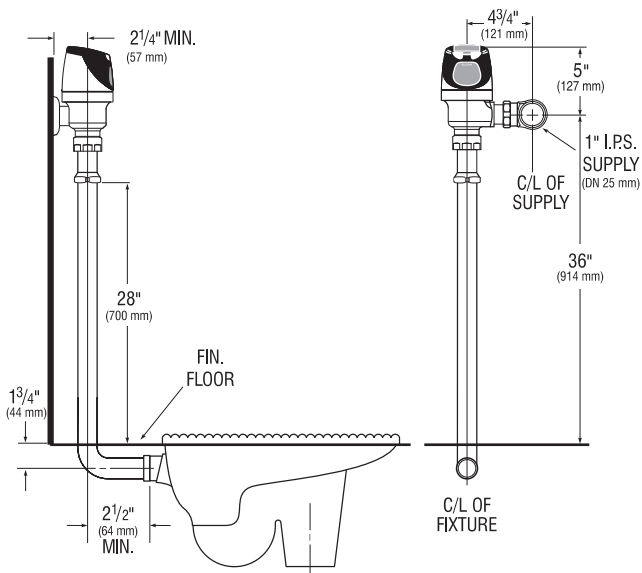

The Model 8137 does not require the use of a Beam Deflector to properly target the user.

SLOAN VALVE COMPANY • 10500 SEYMOUR AVENUE • FRANKLIN PARK, IL 60131

Phone: 1-800-982-5839 or 1-847-671-4300 • Fax: 1-800-447-8329 or 1-847-671-4380 • www.sloanvalve.com