

► **Description**
Exposed, AC Powered, Sensor Activated, Sloan® Optima® SMOOTH™ Water Closet Flushometer for back inlet squat toilets.

► **Flush Cycle**
 Model 137-HWS-1.6 Low Consumption (1.6 gpf/6.0 Lpf)
 Model 137-HWS-2.4 (2.4 gpf/9.0 Lpf)
 Model 137-HWS Water Saver (3.5 gpf/13.2 Lpf)

► **Variations**
 U 1¼" Flush Connection
 DFB Dual Filtered Fixed Bypass Diaphragm
 XYV Less Vacuum Breaker
 YJ Split Ring Pipe Support
 YK Solid Ring Pipe Support

► **Specifications**
Quiet, Exposed, Diaphragm Type, Chrome Plated Closet Flushometer with the following features:

- Flushometer**
- High Chloramine Resistant PERMEX™ Synthetic Rubber Diaphragm with Linear Filtered Bypass and Vortex Cleansing Action™
 - ADA Compliant Metal Oscillating Non-Hold-Open Handle with Triple Seal Handle Packing
 - 1" I.P.S. Screwdriver Bak-Chek® Angle Stop
 - Vandal Resistant Stop Cap
 - Adjustable Tailpiece
 - Vacuum Breaker with Flush Connection
 - Sweat Solder Adapter with Cover Tube and Cast Wall Flange
 - High Copper, Low Zinc Brass Castings for Dezincification Resistance
 - Non-Hold-Open Handle and No External Volume Adjustment to Ensure Water Conservation
 - Low Consumption flush accuracy
 - Handle Packing, Stop Seat and Vacuum Breaker Molded from PERMEX™ Rubber Compound for Chloramine Resistance
 - 100% of the energy used in manufacturing is offset with Renewable Energy Sources – Wind Energy

- Optima SMOOTH Unit**
- ADA Compliant OPTIMA® SMOOTH™ AC Powered Infrared Sensor for automatic "Hands-free" operation
 - Sensor with Automatic Range Adjustment
 - Chrome Plated Metal Sensor Housing
 - Mechanical Manual Override Flush Handle
 - "User in View" Flashing LED
 - 25 to 80 psi Operating Range
 - Vandal Resistant 1/8" Ball-Type Hex Key included

Valve Body, Cover, Tailpiece and Control Stop shall be in conformance with ASTM Alloy Classification for Semi-Red Brass. Valve shall be in compliance to the applicable sections of ASSE 1037, ANSI/ASME A112.19.2, and Military Specification V-29193.

► **Accessories (Specify separately)**

- **Transformers**
 - EL-386** 120 VAC/6 VAC, 50/60 Hz (3 VA) - Plug-in (will operate 1 unit)
 - EL-451** 120 VAC/6 VAC, 50/60 Hz (25 VA) - Box Mount (will operate up to 8 units)

See Accessories Section of the Sloan catalog for details on these and other Flushometer variations.

This space for Architect/Engineer approval	
Job Name _____	Date _____
Model Specified _____	Quantity _____
Variations Specified _____	
Customer/Wholesaler _____	
Contractor _____	
Architect _____	

The information contained in this document is subject to change without notice.



- **ADA Compliant**
- **Automatic**
Sloan SMOOTH™ equipped Flushometers provide the ultimate in sanitary protection and automatic operation. Once the user enters the sensor's effective range and then steps away, the SMOOTH™ Unit initiates the flushing cycle to flush the fixture. State-of-the-art Technology enables override activation without "double flushing" as the user departs (sensor is locked-out for approximately 10 seconds). **True manual override eliminates the need for expensive battery back-up systems.**
- **Hygienic**
The Sloan® Optima® SMOOTH™ Flushometer is the next advancement in hygiene. It uses sensor technology to transform manual installations into electronic, hands-free operation. User makes no physical contact with the Flushometer surface except to initiate the Override Handle when required. Helps control the spread of infectious diseases.
- **Economical**
Automatic operation provides water usage savings over other flushing devices. Reduces maintenance and operation costs. Installation does not require turning off water to the valve.
- **Warranty**
3 year (limited)



Model

137-HWS

Description

Exposed, AC Powered, Sensor Activated, Sloan® Optima® SMOOTH™ Water Closet Flushometer for back inlet squat toilets.

Flush Cycle

- Model 137-HWS-1.6 Low Consumption (1.6 gpf/6.0 Lpf)
- Model 137-HWS-2.4 (2.4 gpf/9.0 Lpf)
- Model 137-HWS Water Saver (3.5 gpf/13.2 Lpf)

ELECTRICAL SPECIFICATIONS

Control Circuit

6 VDC Input
8 Second Arming Delay
72 Hour Sentinel Flush

OPTIMA Sensor Range

Normal Range
(recommended for Water Closets) with 2 - 3 second flush delay: 26" - 32"
(660 mm - 813 mm)

Normal Range
(recommended for Water Closets) with 1 - 2 second flush delay: 26" - 32"
(660 mm - 813 mm)

Reduced Range
(recommended for Urinals) with 1 - 2 second flush delay: 20" - 26"
(508 mm - 660 mm)

OPTIMA Sensor Type

Active Infrared with Automatic Adjustment

Transformer

Sloan Part #EL-386 (Plug-in)
120 VAC, 50/60 Hz Primary
6 VAC, 50/60 Hz Secondary
Class II, 3 VA.

Sloan Part #EL-451 (Box Mount)
120 VAC, 50/60 Hz Primary
6 VAC, 50/60 Hz Secondary
Class II, 25 VA.

Indicator Light

User in View

Operating Pressure

25 - 80 psi (172 - 552 kPa)

DIMENSIONS

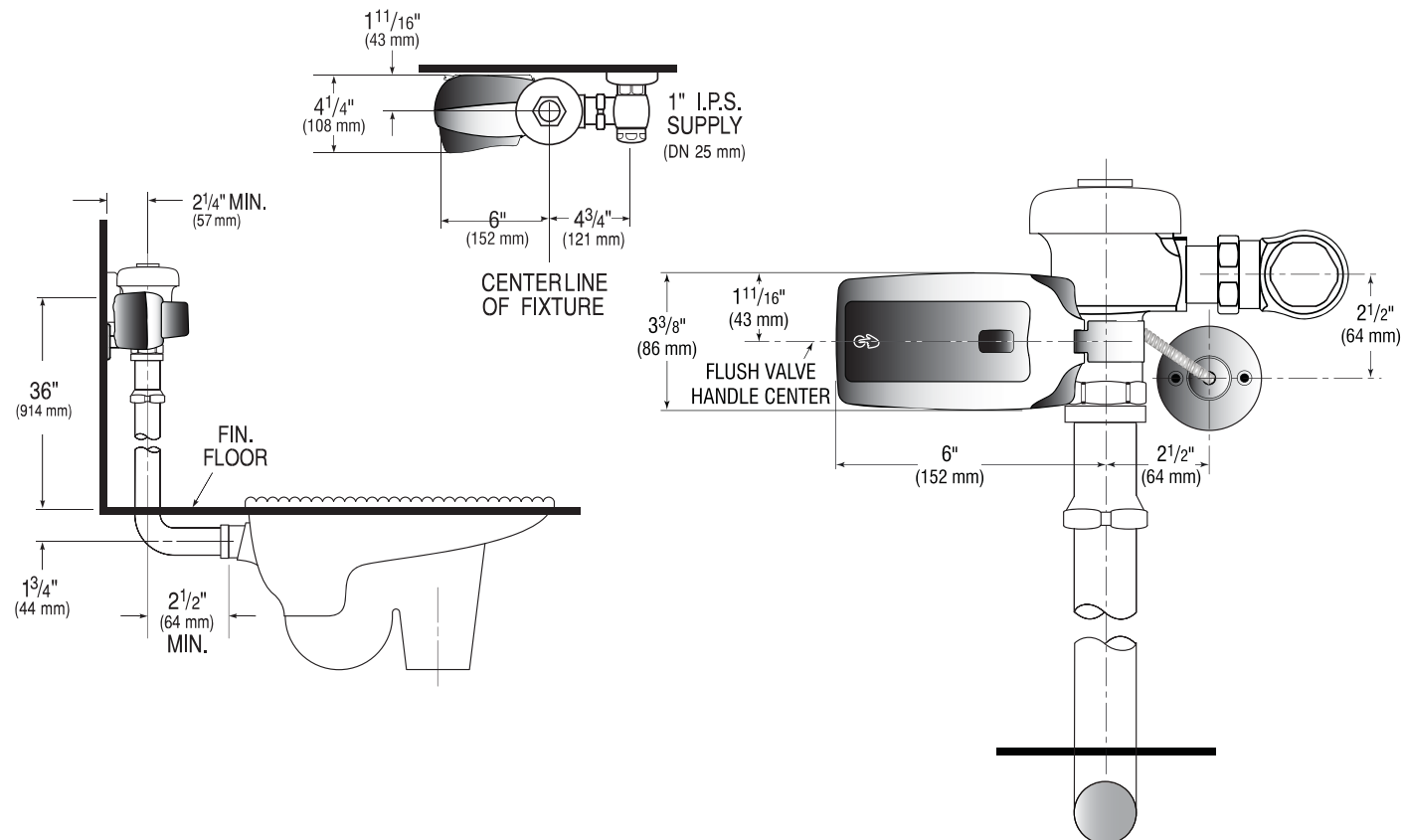

WIRING DIAGRAM

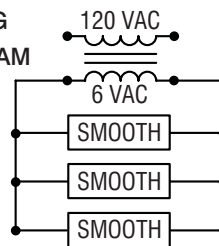

One EL-386 Transformer serves one (1) OPTIMA Closet/Urinal Flushometer.

One EL-451 Transformer serves up to eight (8) OPTIMA Closet/Urinal Flushometers.

OPERATION

1. A continuous, invisible light beam is emitted from the SMOOTH unit's Infrared Sensor.
2. When the user enters the sensor's effective range, the Red LED light in the sensor window flashes for eight seconds. After eight seconds of sensing the user, the light will stop flashing and the unit waits for the user to step away before initiating a flush cycle.
3. When the user steps away, the unit initiates a flush cycle. The unit then automatically resets and is ready for the next user.

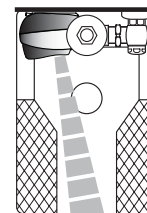
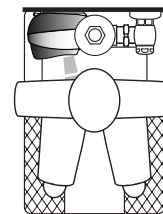
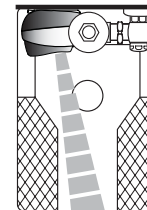

SLOAN VALVE COMPANY • 10500 SEYMOUR AVENUE • FRANKLIN PARK, IL 60131

Phone: 1-800-9-VALVE-9 or 1-847-671-4300 • Fax: 1-800-447-8329 or 1-847-671-4380 • www.sloanvalve.com