

RESS-XDT-U

► **Description**

Battery Powered, Sensor Activated, Sloan[®] Optima[®] Plus Model Retrofit Conversion Kit for Exposed Urinal Flushometers that incorporates a Valve Body with a Tailpiece Connection for Cambridge Brass Teck Valve Control Stop.

► **Flush Cycle**

- Model RESS-XDT-U-0.5 (0.5 gpf/1.9 Lpf)
- Model RESS-XDT-U-1.0 Low Consumption (1.0 gpf/3.8 Lpf)
- Model RESS-XDT-U-1.5 Water Saver (1.5 gpf/5.7 Lpf)
- Model RESS-XDT-U-3.5 (3.5 gpf/13.2 Lpf)

► **Specifications**

Quiet, Exposed, OPTIMA Plus[®], Battery Powered, Sensor Activated Urinal Flushometer Retrofit Conversion Kit with Cambridge Brass Teck Valve Tailpiece Connection with the following features:

- High Chloramine Resistant PERMEX[™] Synthetic Rubber Diaphragm with Linear Filtered Bypass and Vortex Cleansing Action[™]
- ADA Compliant OPTIMA Plus[®] Battery Powered Infrared Sensor for automatic "No Hands" operation
- Infrared Sensor with Multiple-focused, Lobular Sensing Fields for high and low target detection
- Latching Solenoid Operator
- Engineered Plastic Cover with replaceable Lens Window
- Courtesy Flush[™] Override Button
- Four (4) Size AA Batteries factory installed
- "Low Battery" Flashing LED
- Infrared Sensor Range Adjustment Screw
- Initial Set-up Range Indicator Light (first 10 minutes)
- High Copper, Low Zinc Brass Castings for Dezincification Resistance
- No External Volume Adjustment to Ensure Water Conservation
- Low Consumption Flush Accuracy
- Chrome Plated Metal Handle Cap
- Installation Tools Provided
- 100% of the energy used in manufacturing is offset with Renewable Energy Sources – Wind Energy

Valve Body, Tailpiece and Control Stop shall be in conformance with ASTM Alloy Classification for Semi-Red Brass. Valve shall be in compliance with the applicable sections of ASSE 1037, ANSI/ASME A112.19.2 and Military Specification V-29193. Installation conforms to ADA requirements.

See Accessories Section and OPTIMA Accessories Section of the Sloan catalog for details on these and other OPTIMA Plus[®] Flushometer variations.



► **ADA Compliant**

► **Automatic**

Sloan OPTIMA Plus[®] equipped Flushometers provide the ultimate in sanitary protection and automatic operation. There is no need for AC hookups or wall alterations. The Flushometer operates by means of a battery powered infrared sensor. Once the user enters the sensor's effective range and then steps away, the Flushometer Solenoid initiates the flushing cycle to flush the fixture.

► **Hygienic**

User makes no physical contact with the Flushometer surface except to initiate the Override Button when required. Helps control the spread of infectious diseases.

► **Economical**

Automatic operation provides water usage savings over other flushing devices. Reduces maintenance and operation costs.

► **Warranty**

3 year (limited)



This space for Architect/Engineer approval	
Job Name _____	Date _____
Model Specified _____	Quantity _____
Variations Specified _____	
Customer/Wholesaler _____	
Contractor _____	
Architect _____	

RESS-XDT-U

Description

Battery Powered, Sensor Activated, Sloan® Optima® Plus Model Retrofit Conversion Kit for Exposed Urinal Flushometers that incorporates a Valve Body with a Tailpiece Connection for Cambridge Brass Teck Valve Control Stop.

Flush Cycle

- Model RESS-XDT-U-0.5 (0.5 gpf/1.9 Lpf)
- Model RESS-XDT-U-1.0 Low Consumption (1.0 gpf/3.8 Lpf)
- Model RESS-XDT-U-1.5 Water Saver (1.5 gpf/5.7 Lpf)
- Model RESS-XDT-U-3.5 (3.5 gpf/13.2 Lpf)

ELECTRICAL SPECIFICATIONS

Control Circuit

Solid State
6 VDC Input
8 second Arming Delay
24 hour Sentinel Flush

OPTIMA Sensor Type

Active Infrared

OPTIMA Sensor Range

Nominal 15"-30" (381 mm-762 mm), adjustable $\pm 8"$ (203 mm)

Battery Type

Four (4) AA Alkaline

Battery Life

3 years @ 4,000 flushes/month

Indicator Lights

Range Adjustment/Low Battery

Sentinel Flush

Once Every 24 Hours After the Last Flush

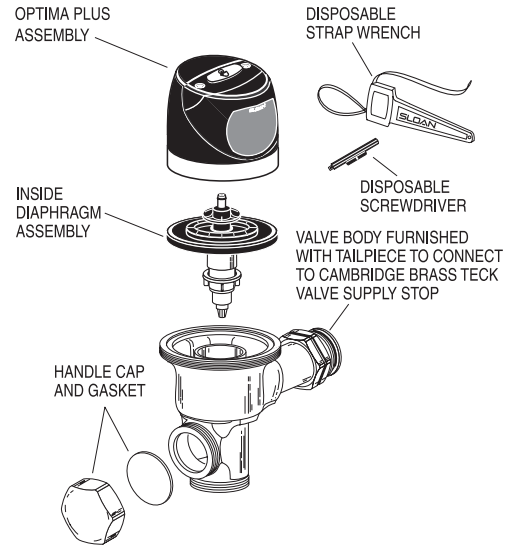

Operating Pressure

15-100 psi (104-689 kPa)

OPERATION

1. A continuous, invisible light beam is emitted from the OPTIMA Plus Sensor.

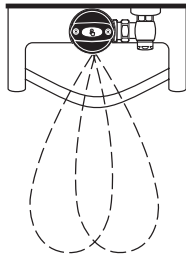

2. As the user enters the beam's effective range (15" to 30") the beam is reflected into the OPTIMA Plus Scanner Window and transformed into a low voltage electrical circuit. Once activated, the Output Circuit continues in a "hold" mode for as long as the user remains within the effective range of the Sensor.

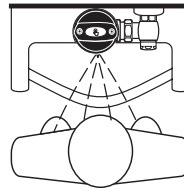

3. When the user steps away from the OPTIMA Plus Sensor, the sensor initiates an electrical signal that operates the Solenoid. This initiates the flushing cycle to flush the fixture. The Circuit then automatically resets and is ready for the next user.

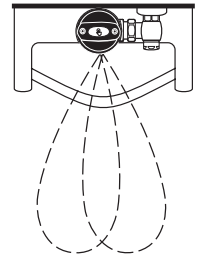

VALVE ROUGH-IN

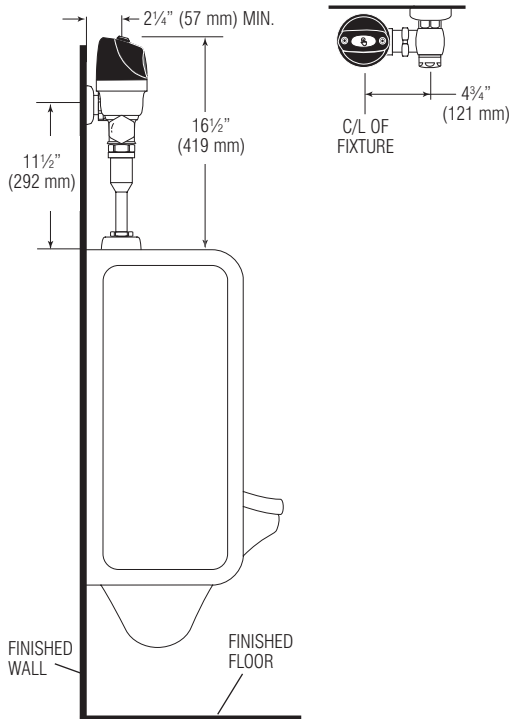

Note: Lens Deflector no longer needed for targeting children or wheel chair users.

SLOAN VALVE COMPANY • 10500 SEYMOUR AVENUE • FRANKLIN PARK, IL 60131

Phone: 1-800-9-VALVE-9 or 1-847-671-4300 • Fax: 1-800-447-8329 or 1-847-671-4380 • www.sloanvalve.com