



## 195 ES-S

► **Description**

Concealed, Sensor Activated, Sloan® Model Urinal Flushometer, for ¾" back spud urinals.

► **Flush Cycle**

- Model 195-0.125 ES-S High Efficiency (0.125 gpf/0.5 Lpf)
- Model 195-0.25 ES-S High Efficiency (0.25 gpf/0.9 Lpf)
- Model 195-0.5 ES-S High Efficiency (0.5 gpf/1.9 Lpf)

► **Specifications**

Quiet, Concealed, Diaphragm Type, Rough Brass Urinal Flushometer with the following features:

- For Flush Volumes 0.125 and 0.25: Dual Linear Filtered Bypass Diaphragm
- For Flush Volume 0.5: Linear Filtered Bypass Diaphragm with Vortex Cleansing Action™
- OPTIMA® EL-1500 Self-Adaptive Infrared Sensor with Indicator Light
- Non-Hold-Open Integral Solenoid Operator
- Chrome Plated Wall Cover Plate (for 2-gang Electrical Box) with Vandal Resistant Screws
- ¾" I.P.S. Wheel Handle Bak-Chek® Angle Stop
- Adjustable Tailpiece
- Vacuum Breaker with Flush Connection
- Spud Coupling for ¾" Concealed Back Spud
- Sweat Solder Adapter
- High Copper, Low Zinc Brass Castings for Dezincification Resistance
- No External Volume Adjustment to Ensure Water Conservation
- Low Consumption Flush Accuracy
- Diaphragm, Stop Seat and Vacuum Breaker Molded from PERMEX® Rubber Compound for Chloramine Resistance

Valve Body, Cover, Tailpiece and Control Stop shall be in conformance with ASTM Alloy Classification for Semi-Red Brass. Valve shall be in compliance with the applicable sections of ASSE 1037. Installation conforms to ADA requirements.

► **L Dimension**

Specify the "L" Dimension for the proper length of the Flush Connection. The "L" Dimension is equal to the Wall Thickness (to nearest whole inch) plus 2¾".

► **Variations**

- DFB** Dual Filtered Fixed Bypass Diaphragm (available on flush volumes 0.5 gpf or greater)
- OR** Override

► **Accessories**

- EL-154** Transformer (120 VAC/24 VAC 50 VA)
- EL-342** Transformer (240 VAC/24 VAC 50 VA)

See Accessories Section and OPTIMA® Accessories Section of the Sloan catalog for details on these and other OPTIMA® Flushometer variations.

► **Fixtures**

Consult Sloan for Sloan brand matching fixture options.



► **Automatic**

Sloan OPTIMA® equipped Flushometers provide the ultimate in sanitary protection and automatic operation. There are no handles to trip or buttons to push. The Flushometer operates by means of an infrared sensor that adapts to its surrounding. Once the user enters the sensor's effective range and then steps away, the Flushometer Solenoid initiates the flushing cycle to flush the fixture.

► **Hygienic**

User makes no physical contact with the Flushometer surface. Helps control the spread of infectious diseases. Twenty-four Hour Sentinel Flush keeps fixture fresh during periods of nonuse.

► **Economical**

Automatic operation provides water usage savings over other flushing devices. Reduces maintenance and operation costs.

► **Practical**

Solid state electronic circuitry assures years of dependable, trouble-free operation. The operational components of the Flushometer are identical to a handle activated Sloan® Flushometer.

► **Warranty**

3 year (limited)



Sloan Valve Company is buying renewable energy certificates to meet 100% of the company's purchased electricity use at its Franklin Park, Illinois facility.



This space for Architect/Engineer approval

Job Name \_\_\_\_\_ Date \_\_\_\_\_

Model Specified \_\_\_\_\_ Quantity \_\_\_\_\_

Variations Specified \_\_\_\_\_

Customer/Wholesaler \_\_\_\_\_

Contractor \_\_\_\_\_

Architect \_\_\_\_\_

# 195 ES-S



► **Description**  
Concealed, Sensor Activated, Sloan® Model Urinal Flushometer, for 3/4" back spud urinals.

► **Flush Cycle**  
 Model 195-0.125 ES-S High Efficiency (0.125 gpf/0.5 Lpf)  
 Model 195-0.25 ES-S High Efficiency (0.25 gpf/0.9 Lpf)  
 Model 195-0.5 ES-S High Efficiency (0.5 gpf/1.9 Lpf)

## ELECTRICAL SPECIFICATIONS

- |  |   |
|--|---|
| <p>► <b>Control Circuit</b><br/>Solid State<br/>24 VAC Input<br/>24 VAC Output<br/>8 Second Arming Delay<br/>24 Hour Sentinel Flush</p> <p>► <b>OPTIMA® Sensor Range</b><br/>Nominal 15" - 30" (381 mm - 762 mm)<br/>Self-adaptive Window: ± 8" (203 mm)</p> | <p>► <b>Solenoid Operator</b><br/>24 VAC, 50/60 Hz</p> <p>► <b>Transformer</b><br/>Sloan Part #EL-154<br/>120 VAC, 50/60 Hz Primary<br/>24 VAC, 50/60 Hz Secondary<br/>Class II, UL Listed, 50 VA.</p> <p>Sloan Part #EL-342<br/>240 VAC, 50/60 Hz Primary<br/>24 VAC, 50/60 Hz Secondary<br/>Class II, UL Listed, 50 VA.</p> |
|--|---|

## WIRING DIAGRAM

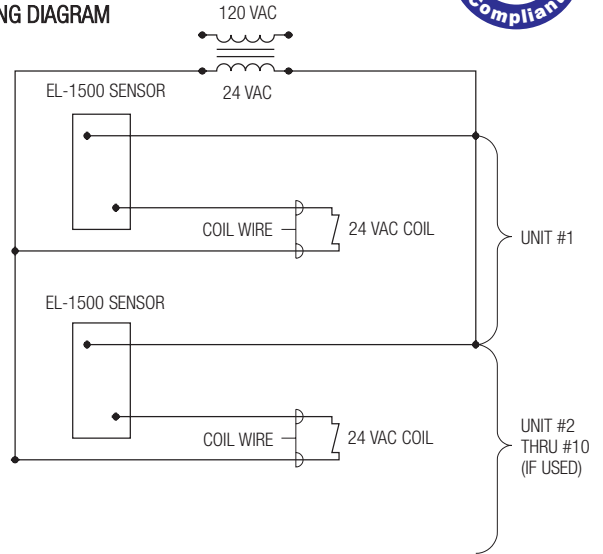

One Transformer serves up to ten (10) OPTIMA® Closet/Urinal Flushometers. Specify number of transformers required accordingly.

## OPERATION

1. A continuous, invisible light beam is emitted from the OPTIMA® Sensor.

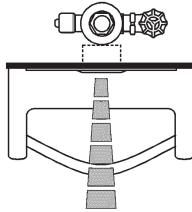

2. As the user enters the beam's effective range (15" to 30") the beam is reflected into the OPTIMA® Scanner Window and transformed into a low voltage electrical circuit. Once activated, the Output Circuit continues in a "hold" mode for as long as the user remains within the effective range of the Sensor.

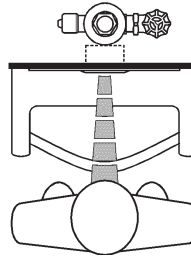

3. When the user steps away from the OPTIMA® Sensor, the circuit immediately initiates an electrical "one-time" signal that operates the Solenoid. This initiates the flushing cycle to flush the fixture. The Circuit then automatically resets and is ready for the next user.

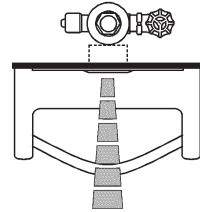

## VALVE ROUGH-IN

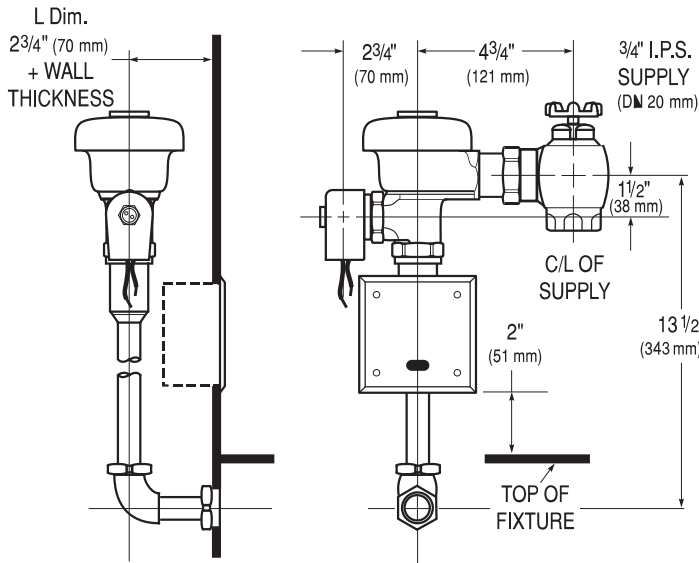

## ELECTRICAL BOX INSTALLATION

### SENSOR LOCATION AND POSITIONING IS CRITICAL

Failure to properly position the electrical boxes to the plumbing rough-in will result in improper installation and impair product performance. All tradesmen (plumbers, electricians, tile setters, etc.) involved with the installation of this product must coordinate their work to assure proper product installation.

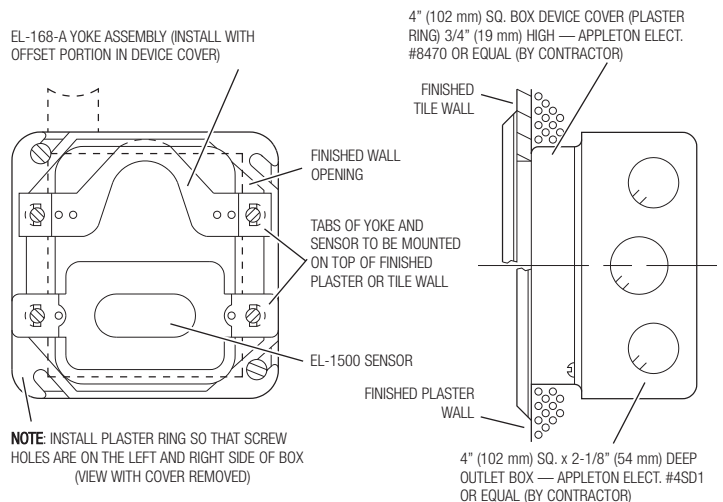

**SLOAN VALVE COMPANY • 10500 SEYMOUR AVENUE • FRANKLIN PARK, IL 60131**

Phone: 1-800-9-VALVE-9 or 1-847-671-4300 • Fax: 1-800-447-8329 or 1-847-671-4380 • www.sloanvalve.com