

186 SMO

► **Description**

Exposed, Battery Powered, Side Mount Sensor Operated Urinal Flushometer for ¾" top spud urinals.

► **Flush Cycle**

- Model 186-1.0-SMO Low Consumption (1.0 gpf/3.8 Lpf)
- Model 186-SMO Water Saver (1.5 gpf/5.7 Lpf)

► **Variations**

- DFB** Dual Filtered Fixed Bypass Diaphragm

► **Specifications**

Quiet, Exposed, Diaphragm Type, Chrome Plated Urinal Flushometer for either left or right hand supply with the following features:

- High Chloramine Resistant PERMEX™ Synthetic Rubber Diaphragm with Linear Filtered Bypass and Vortex Cleansing Action™
- ADA Compliant OPTIMA® Battery Powered Infrared Sensor for automatic "No Hands" operation
- Chrome Plated Infrared Sensor Housing
- Angled Sensor Window
- Manual Override Flush Button
- Four (4) Size C Batteries included
- "Low Battery" Flashing LED with Optional Audio Tone
- "User in View" Flashing LED
- Optional 24-Hour Sentinel Flush
- Infrared Sensor Range Adjustment Screw and Reset Button
- ¾" I.P.S. Screwdriver Bak-Chek® Angle Stop
- Vandal Resistant Stop Cap
- Adjustable Tailpiece
- Vacuum Breaker Flush Connection
- Spud Coupling and Spud Flange for ¾" Top Spud
- Sweat Solder Adapter with Cover Tube and Cast Wall Flange
- High Copper, Low Zinc Brass Castings for Dezincification Resistance
- No External Volume Adjustment to Ensure Water Conservation
- Low Consumption Flush Accuracy
- Stop Seat and Vacuum Breaker molded from PERMEX™ Rubber Compound for Chloramine resistance

Valve Body, Tailpiece and Control Stop shall be in conformance with ASTM Alloy Classification for Semi-Red Brass. Valve shall be in compliance with the applicable sections of ASSE 1037 and ANSI/ASME A112.19.2. Installation conforms to ADA requirements.

► **Specifications**

See Accessories Section and OPTIMA Accessories Section of the Sloan catalog for details on these and other OPTIMA® Flushometer variations.

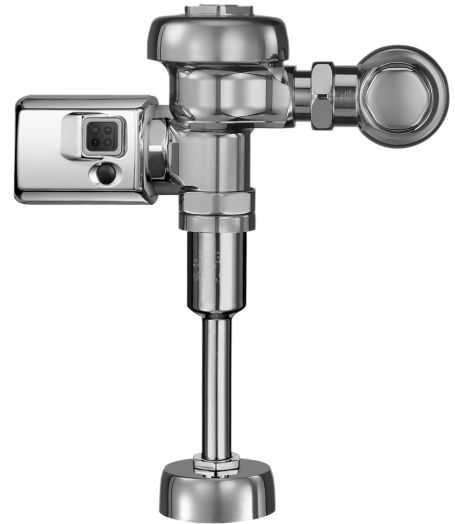

► **Automatic**

Sloan OPTIMA SMO equipped Flushometers provide the ultimate in sanitary protection and automatic operation. There is no need for AC hookups or wall alterations. The Flushometer operates by means of a battery powered infrared sensor. Once the user enters the sensor's effective range and then steps away, the Side Mount Unit initiates the flushing cycle to flush the fixture.

► **Hygienic**

User makes no physical contact with the Flushometer surface except to initiate the Override Button when required. Helps control the spread of infectious diseases. 24-Hour Sentinel Flush keeps fixture fresh during periods of nonuse.

► **Economical**

Automatic operation provides water usage savings over other flushing devices. Reduces maintenance and operation costs. Installation and battery replacement does not require turning off water to the valve.

► **Warranty**

3 year (limited)



| | |
|--|----------------|
| This space for Architect/Engineer approval | |
| Job Name _____ | Date _____ |
| Model Specified _____ | Quantity _____ |
| Variations Specified _____ | |
| Customer/Wholesaler _____ | |
| Contractor _____ | |
| Architect _____ | |

186 SMO



- ▶ **Description**
Exposed, Battery Powered, Side Mount Sensor Operated Urinal Flushometer for 3/4" top spud urinals.
- ▶ **Flush Cycle**
 - Model 186-1.0-SMO Low Consumption (1.0 gpf/3.8 Lpf)
 - Model 186-SMO Water Saver (1.5 gpf/5.7 Lpf)

ELECTRICAL SPECIFICATIONS

- ▶ **Control Circuit**
Solid State
6 VDC Input
- ▶ **OPTIMA Sensor Type**
Infrared Convergence Type Object Lock Detection
- ▶ **OPTIMA Sensor Range**
Nominal 8" - 54" (203 mm - 1372 mm), Factory Set at 24" (610 mm)
- ▶ **Battery Type**
(4) Size C Alkaline
- ▶ **Battery Life**
2 Years @ 3,000 Flushes/Month
- ▶ **Indicator Lights**
User in View/Low Battery
- ▶ **Operating Pressure**
15-100 psi (104-689 kPa)
- ▶ **Operation Features**
(can be turned on and off)
24-Hour Sentinel Flush
Audio Low Battery Tone

VISUAL INDICATOR GUIDE

USER-IN-VIEW L.E.D. — Green light flashes 3 times after 5 second delay when a user is in view. The green light flashes constantly when a user is in view during the 7 minute start up sequence.

BATTERY L.E.D. — Yellow light flashes indicating it is time to replace batteries with four (4) new Type "C" batteries.

OBJECT LOCK SENSOR — Detects user or object.

COURTESY MANUAL FLUSH BUTTON — Allows manual activation of flush when needed.

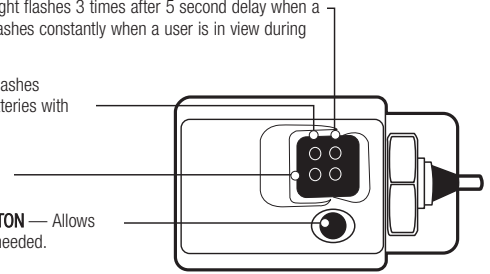

OPERATION

1. A continuous, invisible light beam is emitted from the Object Lock Infrared Sensor.

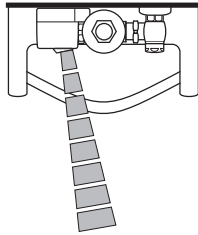

2. As the user enters the beam's effective range, 8" to 54" (203 mm - 1372 mm), the Object Lock Infrared Sensor senses the user.

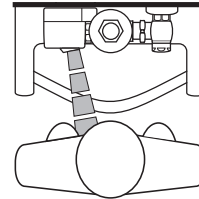

3. When the user steps away from the Object Lock Infrared Sensor, the circuit initiates the flushing cycle to flush the fixture. The Circuit then automatically resets and is ready for the next user.

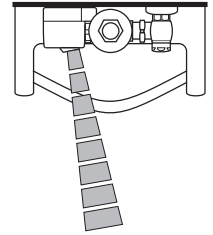

ROUGH-IN

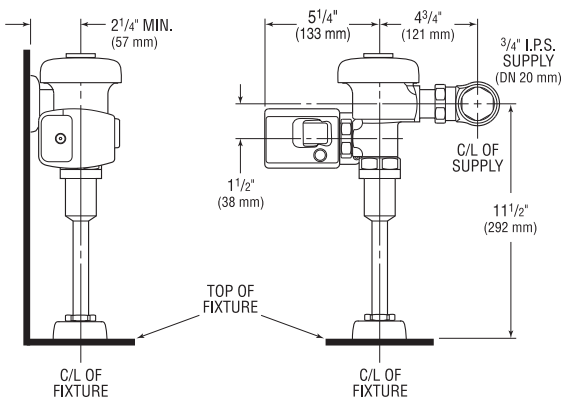

Includes EBV-89-A Side Mount Operator

FUNCTION SETTINGS

Sensor Range Adjustment Screw

Use Sensor Adjustment Tool

Short — + Long

Operation Features

| | | | |
|-------------------------------|-------------------------------|--------------------------------|--------------------------------|
| | | | |
| Switch 1 24 Hours Flush On | Switch 2 24 Hours Flush On | Switch 1 24 Hours Flush Off | Switch 2 24 Hours Flush Off |
| Switch 2 Alarm Tone On | Switch 2 Alarm Tone Off | Switch 2 Alarm Tone On | Switch 2 Alarm Tone Off |

Sensor Range Reset Button

Battery LED (Yellow) Flashing LED = Change Batteries

User-In-View LED (Green) Flashes 3 Times = User Acknowledged and Ready to Operate per Mode Setting

Object Lock Sensor - Detects User or Object

Courtesy Manual Flush Button
Allows Manual Activation of Flush When Needed

SLOAN VALVE COMPANY • 10500 SEYMOUR AVENUE • FRANKLIN PARK, IL 60131

Phone: 1-800-9-VALVE-9 or 1-847-671-4300 • Fax: 1-800-447-8329 or 1-847-671-4380 • www.sloanvalve.com