

152 ES-S TMO SWB

► **Description**

Concealed, Sensor Activated Royal® Model Water Closet Flushometer with True Mechanical Override button, enclosed behind a 13½" x 13½" (343 mm x 343 mm) Wall Frame with Stainless Steel Access Panel, for rear spud bowls.

► **Flush Cycle**

Model 152-1.6 ES-S TMO SWB Low Consumption (1.6 gpf/6.0 Lpf)

► **Specifications**

Quiet, Concealed, Diaphragm Type, Rough Brass Closet Flushometer with the following features:

- PERMEX™ Synthetic Rubber Diaphragm with Dual Filtered Fixed Bypass
- OPTIMA® EL-1500-L Self-Adaptive Infrared Sensor with Indicator Light
- "Walk By" Delay of Eight (8) Seconds Prevents Unintentional Flushes
- User Friendly Three (3) Second Flush Delay
- Courtesy Flush™ Non-Hold-Open True Mechanical Override
- Non-Hold-Open Integral Solenoid Operator
- 1" I.P.S. Wheel Handle Bak-Chek® Angle Stop
- Adjustable Tailpiece
- High Back Pressure Vacuum Breaker Flush Connection with Hex Coupling Nut and Spud Coupling for 1½" Rear Spud
- Sweat Solder Adapter
- High Copper, Low Zinc Brass Castings for Dezincification Resistance
- Fixed Metering Bypass and No External Volume Adjustment to Ensure Water Conservation
- Flush Accuracy Controlled by CID™ Technology
- Wall Box with Stainless Steel Access Panel and Vandal Resistant Screws
- Diaphragm, Stop Seat and Vacuum Breaker molded from PERMEX™ Rubber Compound for Chloramine Resistance

Valve Body, Cover, Tailpiece and Control Stop shall be in conformance with ASTM Alloy Classification for Semi-Red Brass. Valve shall be in compliance with the applicable sections of ASSE 1037. Installation conforms to ADA requirements.

► **Variations**

- TP** Trap Primer

► **Accessories**

- EL-154** Transformer (120 VAC/24 VAC 50 VA)
- EL-342** Transformer (240 VAC/24 VAC 50 VA)

See Accessories Section and OPTIMA® Accessories Section of the Sloan catalog for details on these and other OPTIMA® Flushometer variations.

► **Fixtures**

Consult Sloan for Sloan brand matching fixture options.



► **Automatic**

Sloan OPTIMA® equipped Flushometers provide the ultimate in sanitary protection and automatic operation. There are no handles to trip or buttons to push. The Flushometer operates by means of an infrared sensor that adapts to its surrounding. Once the user enters the sensor's effective range and then steps away, the Flushometer Solenoid initiates the flushing cycle to flush the fixture.

► **Hygienic**

User makes no physical contact with the Flushometer surface except to initiate the Override Button when required. Helps control the spread of infectious diseases. 24-Hour Sentinel Flush keeps fixture fresh during periods of nonuse.

► **Economical**

Automatic operation provides water usage savings over other flushing devices. Reduces maintenance and operation costs.

► **Practical**

Solid state electronic circuitry assures years of dependable, trouble-free operation. The operational components of the Flushometer are identical to a handle activated Royal® Flushometer, proven by over 100 years of experience.

► **Warranty**

3 year (limited)

This space for Architect/Engineer approval	
Job Name _____	Date _____
Model Specified _____	Quantity _____
Variations Specified _____	
Customer/Wholesaler _____	
Contractor _____	
Architect _____	



152 ES-S TMO SWB

Description

Concealed, Sensor Activated Royal® Model Water Closet Flushometer with True Mechanical Override button, enclosed behind a 13½" x 13½" (343 mm x 343 mm) Wall Frame with Stainless Steel Access Panel, for rear spud bowls.

Flush Cycle

Model 152-1.6 SWB ES-S TMO Low Consumption (1.6 gpf/6.0 Lpf)

ELECTRICAL SPECIFICATIONS

Control Circuit

Solid State
24 VAC Input
24 VAC Output
8 Second Arming Delay
3 Second Flush Delay
24-Hour Sentinel Flush

OPTIMA® Sensor Range

Nominal 22" - 42" (559 mm - 1067 mm)
Self-adaptive Window: ± 10" (254 mm)

Solenoid Operator

24 VAC, 50/60 Hz

Transformer

Sloan Part #EL-154
120 VAC, 50/60 Hz Primary
24 VAC, 50/60 Hz Secondary
Class II, UL Listed, 50 VA.

Sloan Part #EL-342

240 VAC, 50/60 Hz Primary
24 VAC, 50/60 Hz Secondary
Class II, UL Listed, 50 VA.

OPERATION

1. A continuous, invisible light beam is emitted from the OPTIMA® Sensor.

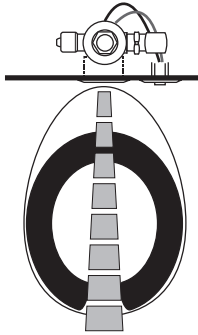

2. As the user enters the beam's effective range (22" to 42") the beam is reflected into the OPTIMA® Scanner Window and transformed into a low voltage electrical circuit. Once activated, the Output Circuit continues in a "hold" mode for as long as the user remains within the effective range of the Sensor.

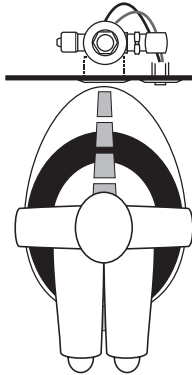

3. When the user steps away from the OPTIMA® Sensor, the circuit waits 3 seconds (to prevent false flushing) then initiates an electrical "one-time" signal that operates the Solenoid. This initiates the flushing cycle to flush the fixture. The Circuit then automatically resets and is ready for the next user.

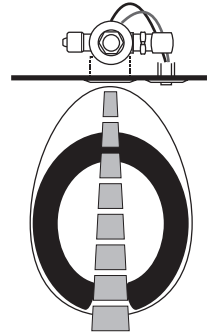

ROUGH-IN

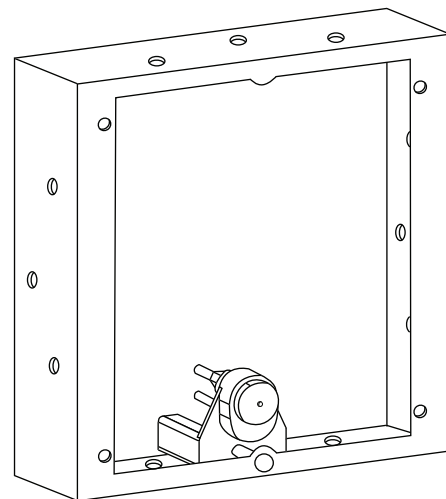
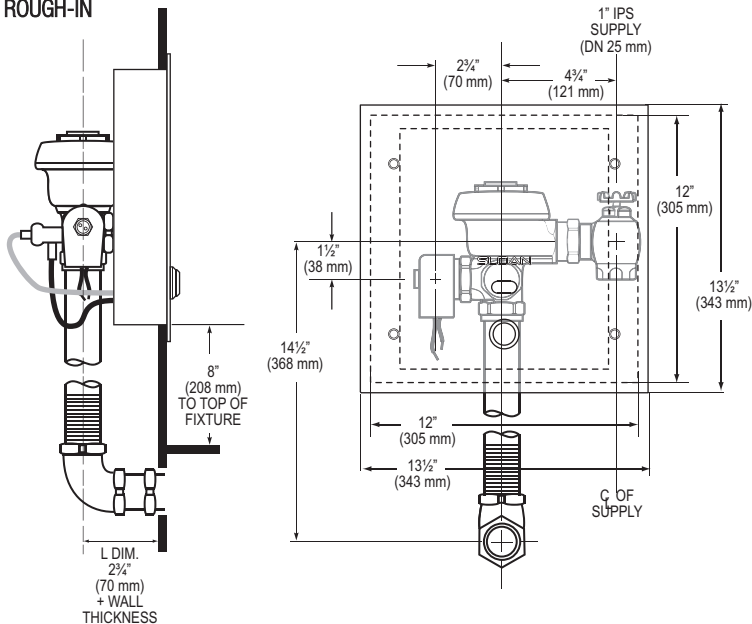

PROPER WALL FRAME ORIENTATION

† Position of Sensor Box can be raised or lowered 1" (25 mm) if in conflict with Handicap Grab Bars.

WIRING DIAGRAM

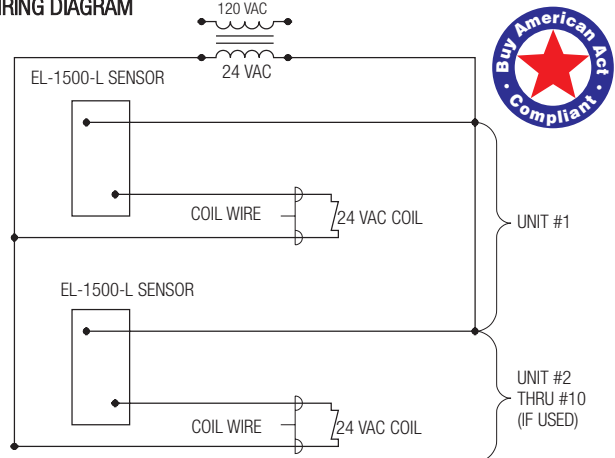

One Transformer serves up to ten (10) OPTIMA® Closet/Urinal Flushometers. Specify number of transformers required accordingly.

Wall Plate Specifications

Sloan Wall Plate Assembly
Frame: 12" x 12" x 4" (305 mm x 305 mm x 102 mm), #16 Gauge Steel
Cover (Access Panel): 13½" x 13½" (343 mm x 343 mm), #16 Gauge, #304 Stainless Steel, #4 Finish
Frame: (4) #8-32 x ¾" Drilled Spanner Flat Head – Spanner Bit Provided

SLOAN VALVE COMPANY • 10500 SEYMOUR AVENUE • FRANKLIN PARK, IL 60131

Phone: 1-800-982-5839 or 1-847-671-4300 • Fax: 1-800-447-8329 or 1-847-671-4380 • www.sloanvalve.com