



Regal® Model 188 XDT Flushometer

188 XDT

188-1.0 XDT

188-0.5 XDT

► Description

Exposed Urinal Flushometer with Adjustable Tailpiece for Cambridge Brass Teck Supply Stop, for 3/4" top spud urinals.

► Flush Cycle

- Model 188 XDT Water Saver (1.5 gpf/5.7 Lpf)
- Model 188-1.0 XDT Low Consumption (1.0 gpf/3.8 Lpf)
- Model 188-0.5 XDT (0.5 gpf/1.9 Lpf)

► Specifications

The Flushometer replaces existing Cambridge Brass Teck valves without having to replace the supply Control Stop.

Quiet, Exposed, Diaphragm Type, Chrome Plated Urinal Flushometer with the following features:

- ADA Compliant Metal Oscillating Non-Hold-Open Handle
- Adjustable Tailpiece to match Teck Supply Stop (supply stop not included)
- Vacuum Breaker Flush Connection
- Spud Coupling and Flange for 3/4" Top Spud
- High Copper, Low Zinc Brass Castings for Dezincification Resistance
- Non-Hold-Open Handle and No External Volume Adjustment to Ensure Water Conservation
- Low Consumption flush accuracy controlled by Para-Flo™ Technology
- Handle Packing, Stop Seat and Vacuum Breaker to be Molded from PERMEX™ Rubber Compound for Chloramine Resistance

Valve Body, Cover and Tailpiece shall be in conformance with ASTM Alloy Classification for Semi-Red Brass. Valve shall be in compliance to the applicable sections of ASSE 1037, ANSI/ASME 112.19.6, and Military Specification V-29193.

► Variations

- U** 1 1/4" Flush Connection and Spud Coupling

Retrofit Installations may require specialized Valve Rough-ins. Consult Sloan Valve Company Installation Engineering Department for assistance.

See Accessories Section of the Sloan catalog for details on these and other Flushometer variations.

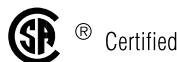
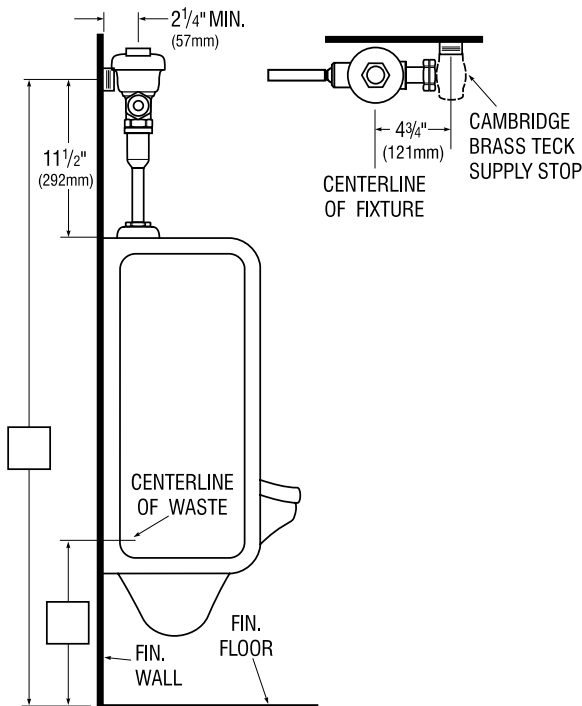

This space for Architect/Engineer approval

The information contained in this document is subject to change without notice.



Made in the U.S.A.

SLOAN VALVE COMPANY • 10500 SEYMOUR AVE. • FRANKLIN PARK, IL. 60131
Ph: 1-800-9-VALVE-9 or 1-847-671-4300 • Fax: 1-800-447-8329 or 1-847-671-4380
<http://www.sloanvalve.com>