

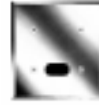

153 XL ES-S



► **Description**

Concealed, Sensor Activated Regal® XL Model Water Closet Flushometer, for floor mounted or wall hung top spud bowls.

► **Flush Cycle**

- Model 153 XL ES-S Water Saver (3.5 gpf/13.2 Lpf)
- Model 153-1.6 XL ES-S Low Consumption (1.6 gpf/6.0 Lpf)

► **Specifications**

Quiet, Concealed, Diaphragm Type, Rough Brass Closet Flushometer for either left or right hand supply with the following features:

- OPTIMA® EL-1500-L Self-Adaptive Infrared Sensor with Indicator Light
- Courtesy Flush™ Override Button
- Non-Hold-Open Integral Solenoid Operator
- Chrome Plated Wall Cover Plate (for 2-gang Electrical Box) with Vandal Resistant Screws
- 1" I.P.S. Wheel Handle Bak-Chek™ Angle Stop
- Adjustable Tailpiece
- Sweat Solder Adapter
- Vacuum Breaker Flush Connection
- Spud Coupling and Flanges for 1½" Exposed Top Spud
- Chrome Plated Exposed Flushometer Parts
- High Copper, Low Zinc Brass Castings for Dezincification Resistance
- Low Consumption flush accuracy controlled by Para-Flo™ Technology
- Diaphragm, Stop Seat and Vacuum Breaker to be Molded from PERMEX™ Rubber Compound for Chloramine Resistance

Valve Body, Cover, Tailpiece and Control Stop shall be in conformance with ASTM Alloy Classification for Semi-Red Brass. Valve shall be in compliance with the applicable sections of ASSE 1037. Installation conforms to ADA requirements.

► **L Dimension**

Specify the "L" Dimension for the proper length of the Flush Connection. The "L" Dimension is equal to the Wall Thickness (to nearest whole inch) plus 2¾". This product is designed to function in applications where the wall thickness is greater than 2", but less than 10¾". If your application is not in this range. Please consult your local Sloan Representative or Sloan Technical Support.

► **Accessories**

- [EL-154](#) Transformer (120 VAC/24 VAC, 50 VA)
- [EL-342](#) Transformer (240 VAC/24 VAC, 50 VA)

See Accessories Section and OPTIMA Accessories Section of the Sloan catalog for details on these and other OPTIMA Flushometer variations.



► **Automatic**

Sloan OPTIMA® equipped Flushometers provide the ultimate in sanitary protection and automatic operation. There are no handles to trip or buttons to push. The Flushometer operates by means of an infrared sensor that adapts to its surrounding. Once the user enters the sensor's effective range and then steps away, the Flushometer Solenoid initiates the flushing cycle to flush the fixture.

► **Hygienic**

User makes no physical contact with the Flushometer surface except to initiate the Override Button when required. Helps control the spread of infectious diseases. Twenty-four Hour Sentinel Flush keeps fixture fresh during periods of nonuse.

► **Economical**

Automatic operation provides water usage savings over other flushing devices. Reduces maintenance and operation costs.

► **Practical**

Solid state electronic circuitry assures years of dependable, trouble-free operation. The operational components of the Flushometer are identical to a handle operated Regal® XL Flushometer.

► **Warranty**

3 year (limited)



This space for Architect/Engineer approval

Job Name _____ Date _____

Model Specified _____ Quantity _____

Variations Specified _____

Customer/Wholesaler _____

Contractor _____

Architect _____

153 XL ES-S



Description

Concealed, Sensor Activated Regal® XL Model Water Closet Flushometer, for floor mounted or wall hung top spud bowls.

Flush Cycle

- Model 153 XL ES-S Water Saver (3.5 gpf/13.2 Lpf)
- Model 153-1.6 XL ES-S Low Consumption (1.6 gpf/6.0 Lpf)

ELECTRICAL SPECIFICATIONS

Control Circuit

Solid State
24 VAC Input
24 VAC Output
8 Second Arming Delay
3 Second Flush Delay
24 Hour Sentinel Flush

OPTIMA Sensor Range

Nominal 22" - 42" (559 mm - 1067 mm)
Self-adaptive Window: ± 10" (254 mm)

Solenoid Operator

24 VAC, 50/60 Hz

Transformer

Sloan Part #EL-154
120 VAC, 50/60 Hz Primary
24 VAC, 50/60 Hz Secondary
Class II, UL Listed, 50 VA.

Sloan Part #EL-342
240 VAC, 50/60 Hz Primary
24 VAC, 50/60 Hz Secondary
Class II, UL Listed, 50 VA.

WIRING DIAGRAM

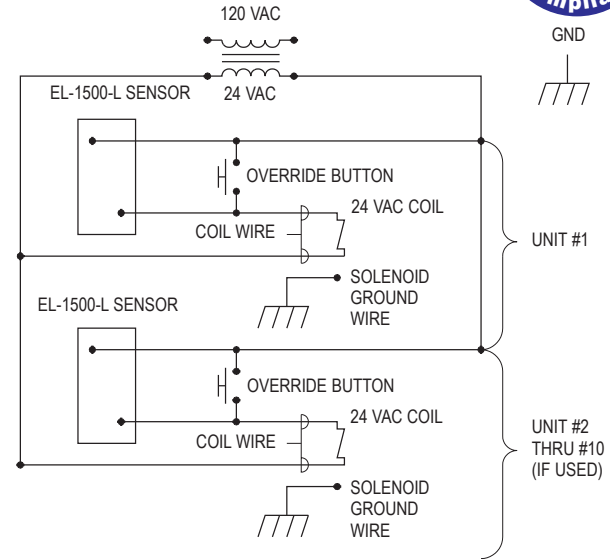

One Transformer serves up to ten (10) OPTIMA Closet/Urinal Flushometers. Specify number of transformers required accordingly.

OPERATION

1. A continuous, invisible light beam is emitted from the OPTIMA Sensor.

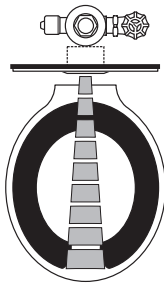

2. As the user enters the beam's effective range (22" to 42") the beam is reflected into the OPTIMA Scanner Window and transformed into a low voltage electrical circuit. Once activated, the Output Circuit continues in a "hold" mode for as long as the user remains within the effective range of the Sensor.

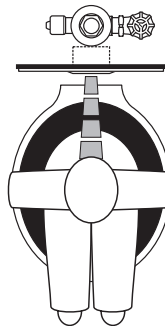

3. When the user steps away from the OPTIMA Sensor, the circuit waits 3 seconds (to prevent false flushing) then initiates an electrical "one-time" signal that operates the Solenoid. This initiates the flushing cycle to flush the fixture. The Circuit then automatically resets and is ready for the next user.

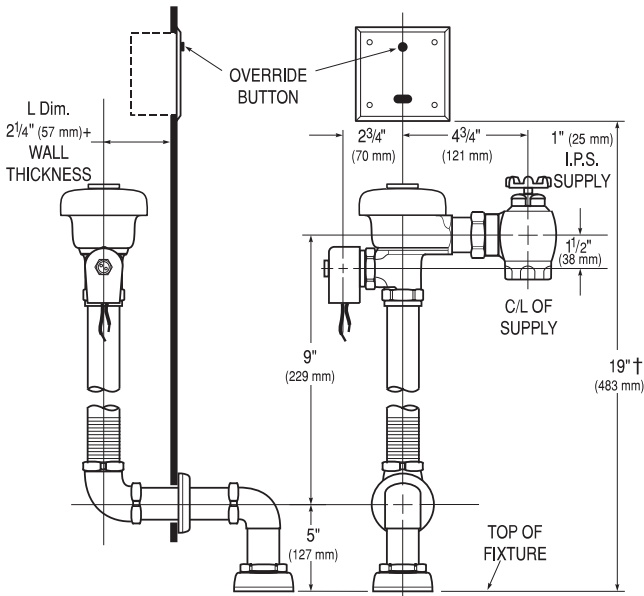
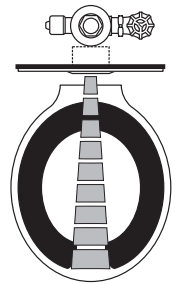

† Position of Sensor Box can be raised or lowered 1" (25 mm) if in conflict with Handicap Grab Bars.

ELECTRICAL BOX INSTALLATION

SENSOR LOCATION AND POSITIONING IS CRITICAL

Failure to properly position the electrical boxes to the plumbing rough-in will result in improper installation and impair product performance. All tradesmen (plumbers, electricians, tile setters, etc.) involved with the installation of this product must coordinate their work to assure proper product installation.

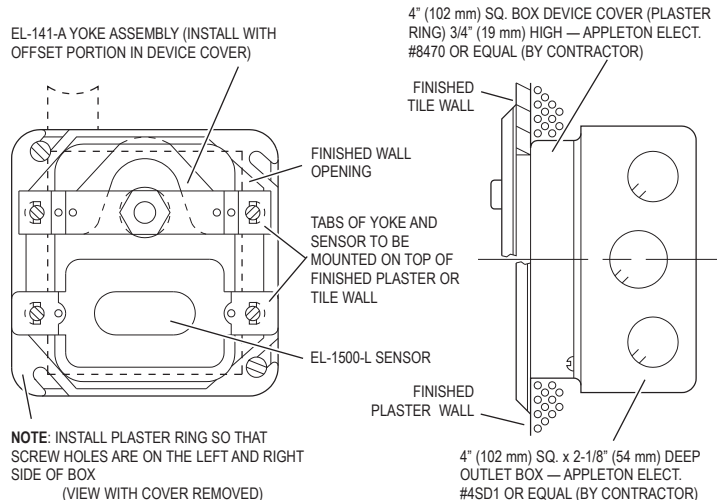

SLOAN VALVE COMPANY • 10500 SEYMOUR AVENUE • FRANKLIN PARK, IL 60131

Phone: 1-800-9-VALVE-9 or 1-847-671-4300 • Fax: 1-800-447-8329 or 1-847-671-4380 • <http://www.sloanvalve.com>