

# EW-63000 EW-63050 SERIES



► **Description**

Triple Station Solid Surface Lavatory System Equipped with Sloan Electronic Sensor Technology.

► **Model**

- EW-63000 Transformer Powered Three Station SloanStone Lavatory System with Integrated Sloan Electronic Sensor Technology
- EW-63050 Battery Powered Three Station SloanStone Lavatory System with Integrated Sloan Electronic Sensor Technology

► **Specifications**

Triple Station Lavatory System with Sloan Electronic Sensor Technology with the following features:

- Integrated Head containing pre-plumbed water paths and electronic components preassembled on a single mounting plate for rapid, easy installation/maintenance
- Sloan Electronic Sensors for hands free point of use activation
- Water Conserving, touch free, on-demand sensors detect user's hands at the point of use preventing unintentional activations
- Sensors are protected from user, reducing damage and vandalism
- 1¼" chrome plated brass drains with grid strainers
- Optional top filled gravity fed manual Soap Dispensers
- Basin and Integrated Head constructed of durable SloanStone solid surface material
- No visible fasteners or obvious access points on the Integrated Head and Basin
- Below deck Mechanical Mixing Valve, standard
- ADA and TAS lavatory Rim Height Standards achieved in a single design
- Aesthetically pleasing soft contoured one-piece continuous Basin
- Top Access Lid with Recessed Allen Key Activation. T-handle Allen wrench standard

**Sloan Electronics feature:**

- Sloan Adjustable Sensor Technology for reliable performance
- Filtered Solenoid with serviceable Strainer
- Chrome plated brass Spouts
- Water saving 0.5 gpm/1.9 Lpm max. Aerator
- 6 VDC Plug-in transformer (Model 63000)
- 4 Alkaline AA Batteries — 2 years life at 8,000 cycles/month (Model 63050)

► **Variations**

- MSD** Manual Soap Dispenser
- FC** Manual Soap Dispenser with Lid Mounted Fill Cap

► **Colors Solid Surface**

- |   |   |
|---|---|
| <input type="checkbox"/> <b>WH</b> White          | <input type="checkbox"/> <b>MLG</b> Matrix Light Gray |
| <input type="checkbox"/> <b>CO</b> Cameo          | <input type="checkbox"/> <b>MDG</b> Matrix Dark Gray  |
| <input type="checkbox"/> <b>BO</b> Bone           | <input type="checkbox"/> <b>MGR</b> Matrix Green      |
| <input type="checkbox"/> <b>PH</b> Peach          | <input type="checkbox"/> <b>MBR</b> Matrix Brown      |
| <input type="checkbox"/> <b>AL</b> Almond         | <input type="checkbox"/> <b>MBO</b> Matrix Bone       |
| <input type="checkbox"/> <b>SH</b> Shell          | <input type="checkbox"/> <b>MLB</b> Matrix Light Blue |
| <input type="checkbox"/> <b>PE</b> Pea            | <input type="checkbox"/> <b>MSA</b> Matrix Sand       |
| <input type="checkbox"/> <b>BI</b> Biscuit        | <input type="checkbox"/> <b>MDB</b> Matrix Dark Blue  |
| <input type="checkbox"/> <b>MWH</b> Matrix White  | <input type="checkbox"/> <b>MDU</b> Matrix DusK       |
| <input type="checkbox"/> <b>MSI</b> Matrix Silver | <input type="checkbox"/> <b>MKH</b> Matrix Khaki      |
| <input type="checkbox"/> <b>MPI</b> Matrix Pink   | <input type="checkbox"/> <b>MSU</b> Matrix Summit     |
| <input type="checkbox"/> <b>MJA</b> Matrix Jade   | <input type="checkbox"/> <b>WNT</b> Walnut            |

► **Colors Plastic Cabinet**

- GRY** Gray
- BLK** Black

► **Warranty**

3 year (limited)

**The New SloanStone™ Lavatory System  
 — The Perfect Match**

The dependability of Sloan electronics combined with the durability of our SloanStone solid surface material creates the ultimate in vandal resistant lavatory systems with a unique designer style.

Having all the serviceable components accessible from the top, including a water shut-off valve, all the electronics, sensors, solenoids and soap components, gives SloanStone sinks the simplest installation and maintenance available. All of this is kept secure from prying hands by a recessed screw and bracket mechanism on each side of the head, which can be loosened with the supplied T-handle wrench. Therefore, there are no visible fasteners on the unit to invite would-be vandals. The infrared sensors are also recess mounted in a stainless steel plate behind the aerator spray head keeping them out of sight of the user, virtually eliminating potential damage to the sensor windows and making this a true water conserving on-demand unit.

A durable plastic cabinet conceals the drain lines, supply stops and mechanical mixing valve; while dual drains complete the exclusive features list that sets SloanStone apart from the competition.



The lavatory system is designed to comply with all applicable ADA, UFAS, Texas Accessibility Standards (T.A.S.), and ANSI Z124.3 and Z124.6 accessibility guidelines when mounted at the recommended rim height.

Sloan Electronics are:



Listed by I.A.P.M.O.

This space for Architect/Engineer approval	
Job Name _____	Date _____
Model Specified _____	Quantity _____
Variations Specified _____	
Customer/Wholesaler _____	
Contractor _____	
Architect _____	

The information contained in this document is subject to change without notice.

# EW-63000 EW-63050

## SERIES

### Triple Station Lavatory System

#### OPERATION

As the user's hands enter the beam's effective range, the beam is reflected back into the sensor receiver and activates the solenoid valve allowing water to flow from the spout. Water will flow until user's hands are removed or until the time out limit is reached.

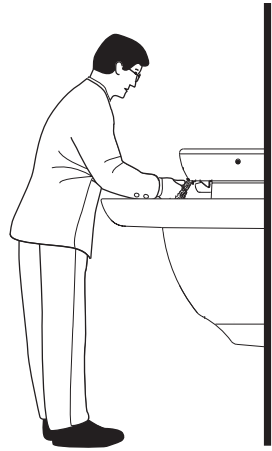

#### SLOANSTONE COLORS

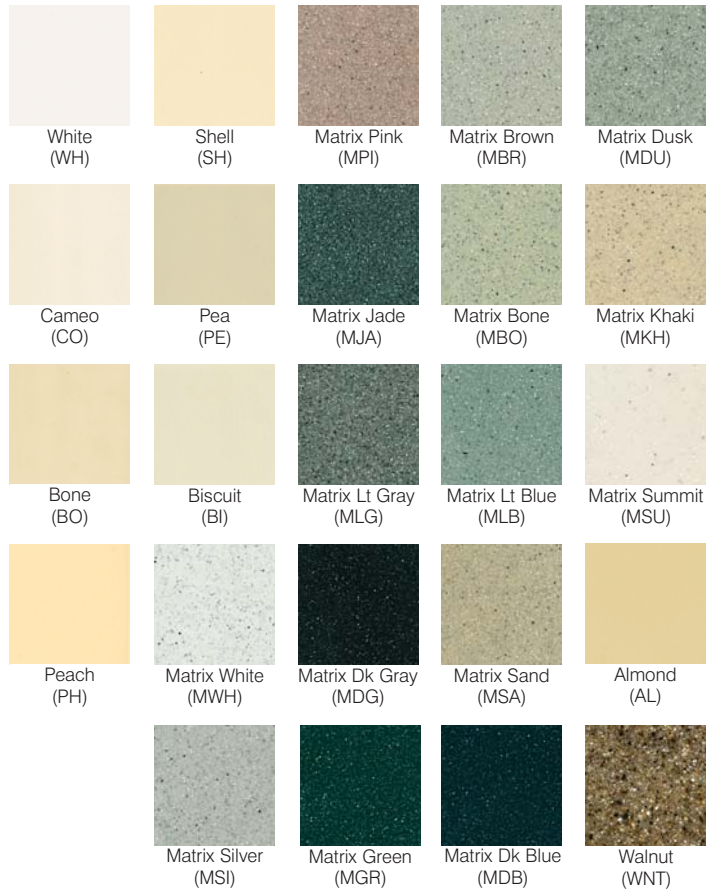

#### ROUGH-IN

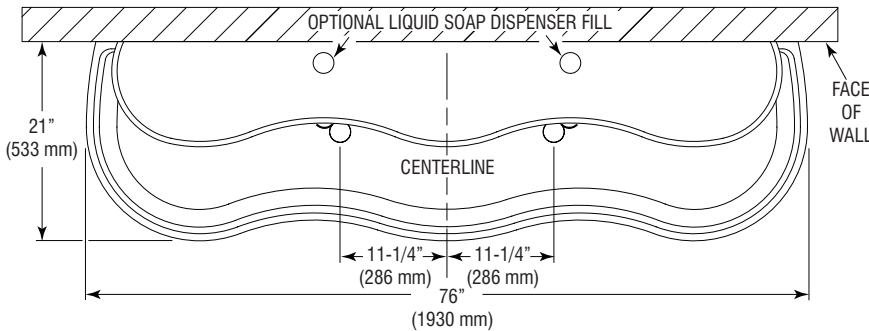

Expanded color options available at: [www.sloanstonesinks.com](http://www.sloanstonesinks.com).  
For in stock availability and quick-ship options please contact your local Sloan representative.

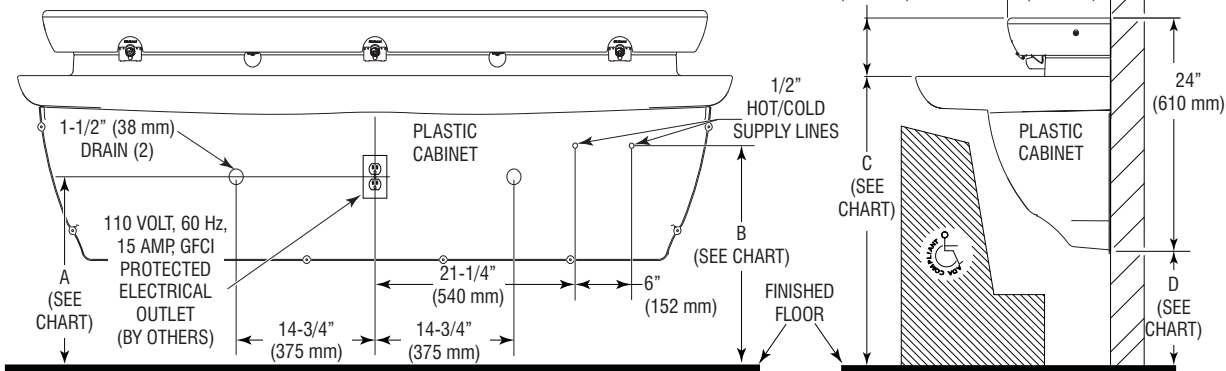

† When no mirror is required above the basin.

DIMENSION DESCRIPTION	T.A.S. † AGES 4-10	T.A.S. † AGES 11-15	A.D.A. STANDARD
A ROUGH-IN, DRAIN	20" (508 mm)	22" (559 mm)	24" (610 mm)
B ROUGH-IN, SUPPLY	23" (584 mm)	25" (635 mm)	27" (686 mm)
C RECOMMENDED RIM HEIGHT	29-3/4" (756 mm)	31-3/4" (806 mm)	33-3/4" (857 mm)
D FLOOR CLEARANCE	12-1/16" (306 mm)	14-1/16" (357 mm)	16-1/16" (408 mm)

For additional technical information, contact the Sloan Installation Engineering Department at 1-888-SLOAN-14 (1-888-756-2614) or [techsupport@sloanvalve.com](mailto:techsupport@sloanvalve.com).

**SLOAN VALVE COMPANY • 10500 SEYMOUR AVENUE • FRANKLIN PARK, IL 60131**

Phone: 1-800-982-5839 or 1-847-671-4300 • Fax: 1-800-447-8329 or 1-847-671-4380 • [www.sloanvalve.com](http://www.sloanvalve.com)