

## Optima Plus® EBF-625/EBF-655

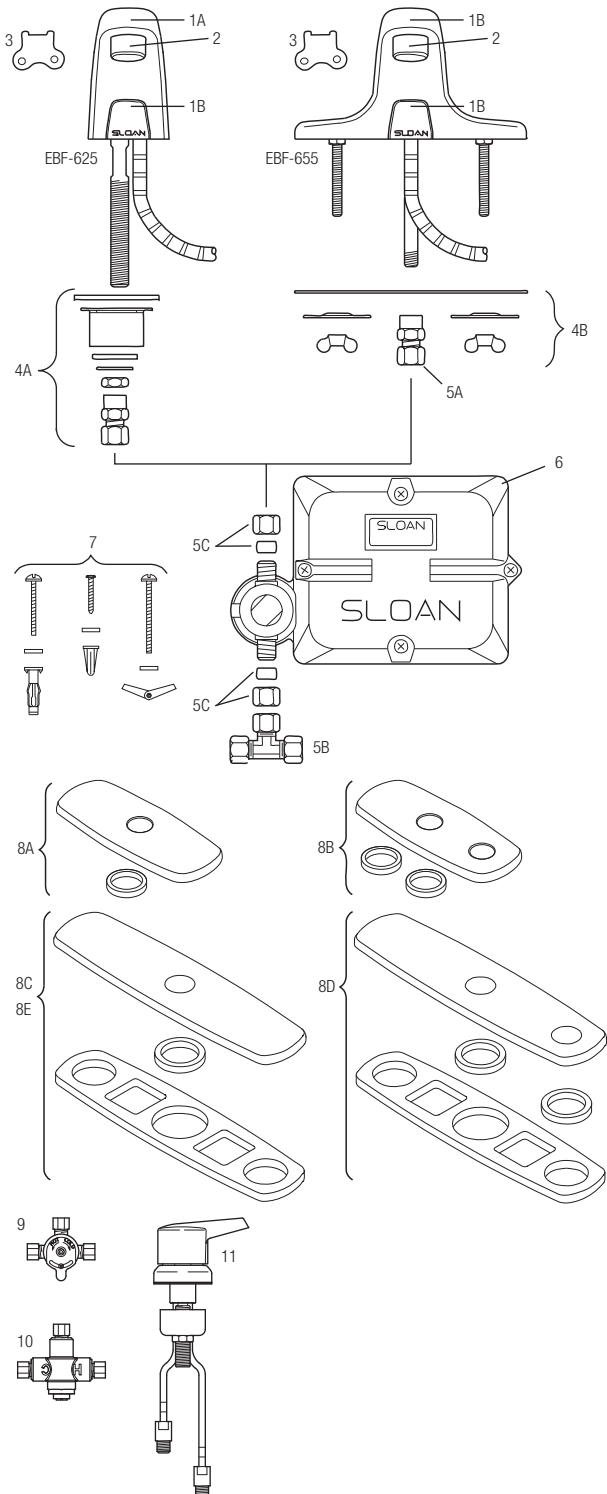
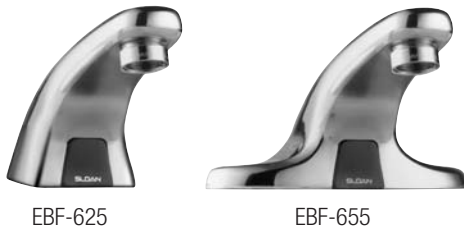

### PARTS LIST—EBF-625 AND EBF-655 FAUCETS

(Known as EBF-615-/EBF-650 Prior to September 2008)

Item No.	Code No.	Part No.	Description
1A.	<b>0315083</b>	EBF-120-A	Pedestal Faucet Spout and Sensor assembly (EBF-625)
1B.	—	EBF-81-A	Faucet Spout and Sensor assembly (EBF-655)
2.	<b>3365092</b>	ETF-1023-A	0.5 gpm (1.9 lpm) Spray head with Key
	<b>3365093</b>	ETF-1024-A	2.2 gpm (8.3 lpm) aerator Spray head with Key
		F-175-1	2.2 gpm (8.3 lpm) laminar Flow Spray head
3.	<b>0305927</b>	ETF-435	Replacement Key only for ETF-1023-A and ETF-1024-A
4A.	<b>0315085</b>	EBF-123-A	Faucet mounting Kit for EBF-625
4B.		ETF-546-A	Faucet mounting Kit for EBF-655
5A.	<b>0365058</b>	ETF-547	1/8" NPT pipe to 3/8" Tube Compression Fitting Connection
5B.	<b>3365461</b>	ETF-617	3/8" Bak-Chek Tee Compression Fitting
5C.	<b>3315029</b>	EBF-113-A	Single Solenoid Supply Kit
6.	<b>0315104</b>	EBF-60-A	Control module assembly
7.	<b>3315018</b>	EBF-79-A	Mounting hardware Kit for Control module assembly
8A.	<b>3365302</b>	ETF-607-A	4" (102 mm) Centerset Trim plate for EBF-625
8B.	—	MIX-101-A	4" (102 mm) Centerset Trim plate for EBF-625 with optional mixing Valve
8C.	<b>3365303</b>	ETF-608-A	8" (204 mm) Centerset Trim plate for EBF-625
8D.	—	MIX-106-A	8" (204 mm) Centerset Trim plate for EBF-625
8E.	<b>3365119</b>	ETF-578-A	8" (204 mm) Centerset Trim plate for EBF-655
	<b>0315040PK</b>	EBF-80-A	Sensor replacement Kit
	<b>0315254</b>	EBF-1011-A	Solenoid replacement Kit
	—	EBF-1004-A	Solenoid Filter replacement Kit (includes Filter Screen and o-ring)
<b>OPTIONAL MIXING VALVES</b>			
9.	<b>3326009</b>	MIX-60-A	Below Deck Mechanical Water Mixing Valve (BDM Variation)
10.	<b>0326045</b>	MIX-135-A	Below Deck Thermostatic Water Mixing Valve (BDT Variation)
11.	—	MIX-110-AA	Optimix® Deck Mounted Water Mixing Valve (only available for EBF-625 faucets)

NOTE: The information contained in this document is subject to change without notice.

— in Item No. column = Not shown in illustration  
 — in Code No. and Part No. column = Not sold separately

Hand Hygiene

## Optima Plus® EBF-625/EBF-655

### TROUBLESHOOTING GUIDE

#### 1. Faucet does not stop delivering water or continues to drip after user is no longer detected (automatic shut-off fails even when batteries are removed).

- A. Solenoid valve has been connected backwards.  
Disassemble solenoid valve compression fittings at both the inlet and outlet positions. The water should flow from inlet through the solenoid valve to the outlet according to the direction of the arrow shown on the side of the solenoid valve. Reconnect the compression fittings in the correct orientation.
- B. Solenoid valve is dirty.  
Back-flush by reversing water flow (opposite to the direction shown by the arrow on the side of the solenoid valve) through the solenoid valve. Reconnect the compression fittings in the correct orientation. Activate faucet.
- C. Solenoid valve module is not working properly.  
Replace EBF-1011-A Solenoid valve module.

#### 2. Sensor troubleshooting LED does not function (red indicator light does not flash during set-up procedure).

- A. No battery power is being supplied to sensor.  
Ensure that the batteries are installed properly. Check that the orientation of each battery matches the positive (+) and negative (-) symbols shown on the bottom of the battery compartment. Reinsert the battery compartment into the control module.
- B. Insufficient battery power is being supplied to sensor.  
One (or more) of the batteries is "dead". To ensure proper operation, insert four (4) new "C" cell alkaline batteries. Check that the orientation of each battery matches the positive (+) and negative (-) symbols shown on the bottom of the battery compartment. Reinsert the battery compartment into the control module.
- C. Sensor cable is not properly inserted.  
Disconnect and reconnect sensor cable to the control module.
- D. Sensor range is set at minimum distance. Increase sensor range.  
Use a small philips screwdriver to turn the potentiometer screw (white screw in blue base) clockwise.
- E. Control module assembly is not working properly.  
Replace EBF-60-A control module assembly.

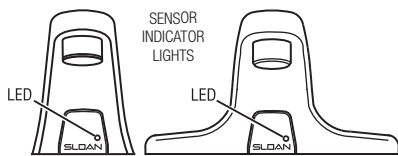

#### 3. The water temperature is too hot or too cold on faucet connected to hot and cold water supply lines with two Bak-Chek.

- A. Supply stops are not adjusted properly.  
Adjust supply stops.

NOTE: A thermostatic mixing valve may be required on some systems.

#### 4. Faucet does not deliver any water when sensor is activated.

**INDICATOR:** Solenoid valve produces audible "CLICK." Water supply valve is closed.

- A. Open the water supply.

**INDICATOR:** Solenoid valve DOES NOT produce an audible "CLICK."

- A. Disconnect and reconnect solenoid lead to the control module, if solenoid lead is not properly connected to the control module. Batteries are not installed properly. Check that the orientation of each battery matches the positive (+) and negative (-) symbols shown on the bottom of the battery compartment. Reinsert the battery compartment into the control module. The troubleshooting LED should flash RED when a user is detected.

#### 5. Faucet delivers only a slow flow or dribble when sensor is activated.

- A. Water supply valve is partially closed.  
Completely open the supply stop(s).
- B. Solenoid filter is clogged.  
Remove, clean, and reinsert.  
Replace EBF-1004-A solenoid filter kit, if necessary.
- C. Aerator or spray head is clogged.  
Remove, clean, and reinsert.

#### BATTERY REPLACEMENT

The Sloan Optima Plus EBF-625 and EBF-655 battery powered, sensor activated lavatory faucets are furnished with four (4) "C" cell alkaline batteries that provide up to two (2) years of operation (8000 cycles per month). A flashing LED signal indicates that battery power will be depleted within one (1) month. Replace batteries with four (4) new "C" cell alkaline batteries.

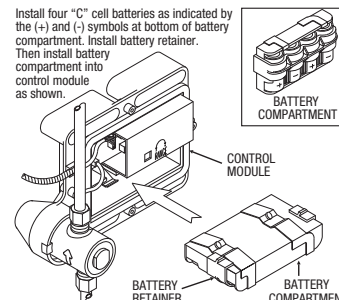

Remove the cover of the control module by unscrewing the four (4) cover screws located at the center of each side.

Remove the battery compartment from the control module by gently pulling straight out with a firm grip. Spread the ends of the battery retainer and remove it from the battery compartment. Remove the old batteries and insert four (4) fresh "C" cell alkaline batteries into the battery compartment until locked into place.

NOTE: Battery retainer MUST be installed as shown. If installed upside-down, it will not install into the control module. Reinsert the battery compartment into the control module as shown.

Place cover over the control module and use the four (4) screws provided to attach it. Cover can be installed in only orientation.

IMPORTANT: Install ALL four (4) cover screws for proper installation.

#### CLEAN SCREEN FILTER

Before cleaning the screen filter, turn off water supply at the supply stop(s). Activate the faucet to relieve any pressure in the system. Unscrew the filter plug and remove it from the solenoid valve housing. Carefully pull the screen filter with attached rubber seals out from the solenoid valve housing.

Clean the screen filter using fresh tap water only. If necessary, use a small brush to clean. Use caution while cleaning to prevent damage to the solenoid screen filter. If any filter components are damaged, order Filter Replacement Kit (EBF-1004-A).

Carefully replace the screen filter into the groove of the solenoid valve housing. Examine the filter plug o-ring for wear or damage; replace if necessary. If necessary, lubricate the filter plug o-ring with water to keep it in place in the groove of the filter plug. Screw the filter plug into the solenoid valve housing.

Turn on the water supply at the supply stop(s). Activate the faucet to purge any air from the system lines. Check for leaks and repair, as necessary.

**When assistance is required, please contact  
Sloan Valve Company Installation Engineering  
Department at: 1-888-SLOAN-14 (1-888-756-2614).**

