

LINO EAF-250

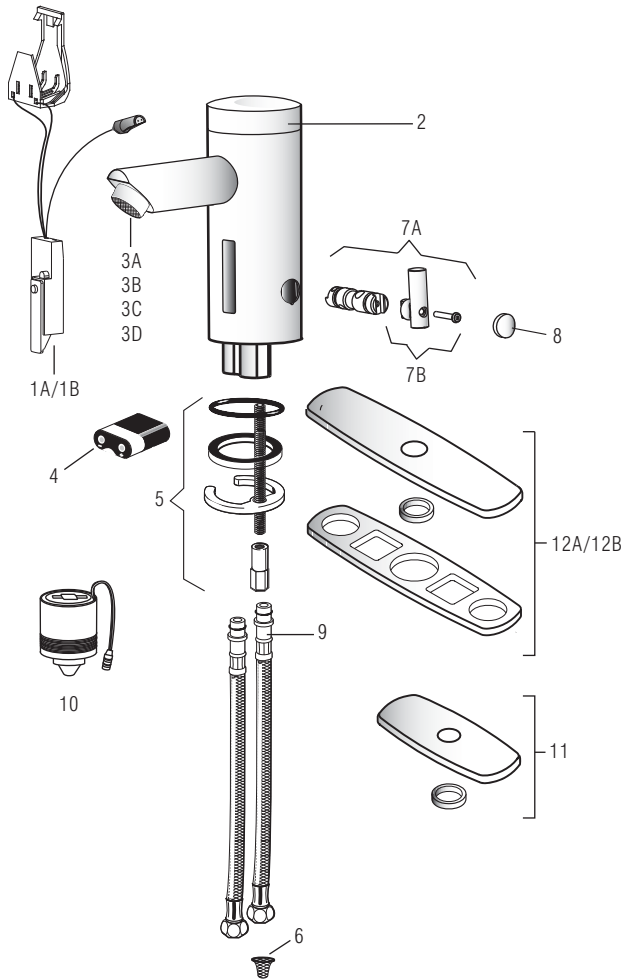

EAF-250 Series Faucet date code 1101 and newer. Product revised to make spray head vandal resistant without need for special spray. EAF-15 only works on product date code 1052 and older.



PARTS LIST—EAF-250 FAUCETS

Item			
No.	Code No.	Part No.	Description
1A.	0335019	EAF-21-A	Faucet Sensor Assembly without <i>i.q.-cliq™</i>
1B.	0335018	EAF-20-A	Faucet Sensor Assembly with <i>i.q.-cliq™</i>
2.	0335027	EAF-27	Cap
3A.	0335012	EAF-15	0.5 gpm (1.9 Lpm) VR Aerator Spray Head – Pre 03/2011
3B.	0335008	EAF-10	2.2 gpm (8.3 Lpm) Aerator Spray Head
3C.	0335011	EAF-13	2.2 gpm (8.3 Lpm) Laminar Flow Spray Head
3D.	0335029	EAF-51	0.35 gpm (1.3 Lpm) Multi-Laminar Spray Head
4.	3335018	EAF-1003	Battery Replacement Kit
5.	0335000	EAF-1	Faucet Mounting Kit
6.	0335007	EAF-9	Strainer (Filter)
7A.	0335019	EAF-1004	Mixer Handle Assembly and Cartridge
7B.	3335020	EAF-1005	Handle Repair Kit
8.	3335022	EAF-1007	Handle Cap
9.	3335023	EAF-1008	13" (330 mm) Flexible Supply Hose
10.	0335001	EAF-2	Solenoid
11.	3365468	ETF-312-A	Trim Plate for 4" Centerset Sink
—	0362011	SFP-11-A	Use when needing 4" for EAF-35-A extension
12A.	3365024	ETF-510-A	Trim Plate for 8" Centerset Sink
12B.	3362022	SFP-22-A	Use when needing 8" for EAF-35-A extension
13.	3335035	EAF-35-A	Faucet Extension Kit
14.	3335046	EAF-40-A	2-1/4" Faucet Extension Kit. Raises faucet such that outlet height complies with California Office of Statewide Health Planning and Development

— = Not shown in illustration

i.q.-cliq™ SETTINGS

Function	Press Button	LED Signal
Continuous Run – 2 minute default setting (adjustable from 1 – 20 minutes)	1 time for 2 seconds	5 short flashes
reset:	1 time or will reset automatically after 2 minutes	
Temporary Off	2 times (double click)	5 short flashes followed by periodic flashing
reset:	1 time or will reset automatically after 2 minutes	
Auto Set Range Adjustment	2 times (double click) and then 1 time for 5 seconds	5 short flashes followed by 4 short flashes

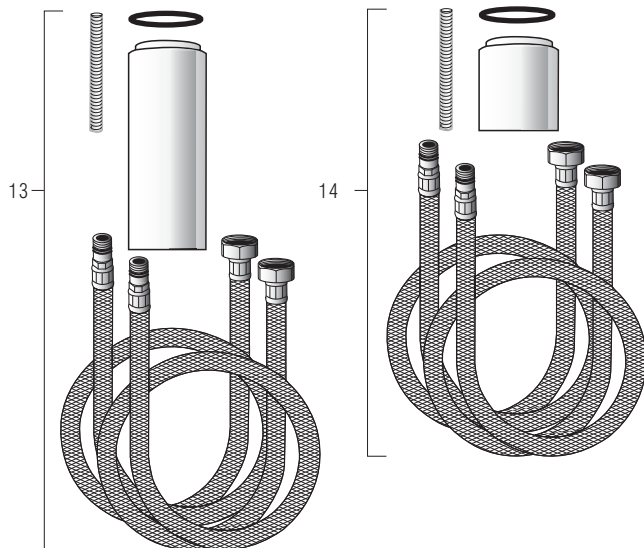

LINO EAF-250**TROUBLESHOOTING GUIDE****1. Faucet does not function.**

- A. "Permanent Off" activated.
Press button on faucet throat one time.

2. Faucet delivers water in an uncontrolled manner.

- A. Faucet is not working properly.
Contact Sloan Technical Support at
1-888-SLOAN-14 (1-888-756-2614).

3. Faucet does not deliver any water when Sensor is activated.

INDICATOR: Solenoid valve produces an audible "CLICK."

- A. Water supply stop(s) closed.
Open water supply stop(s).
- B. Water supply stop strainer(s) clogged.
Remove, clean, and reinstall water supply stop strainer(s).
Replace strainer(s) if required.

INDICATOR: Solenoid valve DOES NOT produce an audible "CLICK."

- A. Battery low (battery powered models).
Replace battery (refer to Battery Replacement on page 184).

4. Faucet delivers only a slow flow or dribble when Sensor is activated.

- A. Water supply stop(s) are partially closed.
Completely open water supply stop(s).
- B. Water supply stop strainer(s) clogged.
Remove, clean, and reinstall water supply stop strainer(s).
Replace strainer(s) if required.
- C. Aerator is clogged.
Remove, clean, and reinstall Aerator. Replace Aerator if required.
- D. Faucet is not working properly.
Contact Sloan Technical Support at
1-888-SLOAN-14 (1-888-756-2614).

5. Faucet does not stop delivering water or continues to drip after user is no longer detected.

- A. Faucet is not working properly.
Contact Sloan Technical Support at
1-888-SLOAN-14 (1-888-756-2614).

6. LED indicator blinks when faucet is in use.

- A. Battery low (battery powered models).
Replace battery (refer to Battery Replacement on page 184).

7. The water temperature is too hot or too cold on a faucet connected to hot and cold supply lines.

- A. Supply Stops are not adjusted properly.
Adjust Supply Stops.
- B. For models with integral mixing valve – Mixing valve is set improperly for the water temperature desired.
Rotate mixing valve handle clockwise to decrease water temperature or counterclockwise to increase water temperature.

OPERATION

As the user's hands enter the beam's effective range, the beam is reflected back into the sensor receiver and activates the solenoid valve allowing water to flow from the faucet. Water will flow until the hands are removed or until the faucet reaches its automatic time out limit setting.

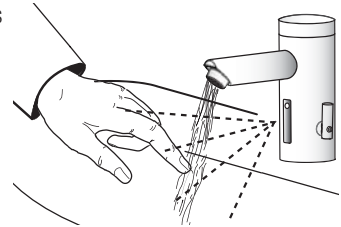
**CARE AND CLEANING INSTRUCTIONS**

DO NOT use abrasive or chemical cleaners (including chlorine bleach) to clean faucet that may dull the luster and attack the chrome or special decorative finishes. Use ONLY mild soap and water, then wipe dry with clean cloth or towel. While cleaning the bathroom tile, protect the faucet from any splattering of cleaner. Acids and cleaning fluids will discolor or remove chrome plating.

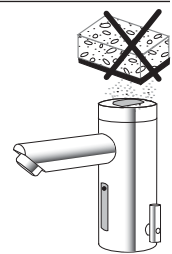

When assistance is required, please contact Sloan Technical Support at: 1-888-SLOAN-14 (1-888-756-2614).